

**TÜRKİYE ODALAR VE BORSALAR BİRLİĞİ**

Dumlupınar Bulvarı No:252 (Eskişehir Yolu 9. Km.) 06530 /ANKARA

www.tobb.org.tr - tobb@hs01.kep.tr

Sayı : E-34221550-045.99-9352

Tarih: 03.07.2026

Konu : İDOP Erken Piyasa Katılımı Toplantısı Hakkında

**Tüm Odalar
(Genel Sekreterlik)**

Tarım ve Orman Bakanlığı tarafından Birliğimize iletilen yazıda, Türkiye İklimle Dirençli Ormancılık Projesi (İDOP) kapsamında gerçekleştirilecek "Dijital Telsiz Haberleşme Sistemi Alımı" ihalesi öncesinde, ihale dokümanlarının nihai hale getirilmesine katkı sağlaması amacıyla, piyasadaki bağılayıcı olmayan teknik geri bildirimlerin alınması için Erken Piyasa Katılımı (Early Market Engagement - EME) sürecinin yürütülmekte olduğu belirtilerek, söz konusu süreç kapsamında 03.07.2026 tarihinde saat 15.00'te çevrim içi Erken Piyasa Katılımı (EME) toplantısı düzenleneceği bildirilmektedir.

Bahse konu toplantının davet metni ve ilgili dokümanlar Orman Genel Müdürlüğü internet sitesinde <https://www.ogm.gov.tr/idop> yer almakta olup, ilgili üyelerinize duyurulması hususunda gereğini rica ederim.

Saygılarımla,

*e-imza*Mustafa SARAÇÖZ
Genel Sekreter

EK:

- 1- EK-1 (10 Sayfa)
- 2- EK-2 (57 Sayfa)



Evrakı Doğrulamak İçin : <https://belgedogrula.tobb.org.tr/belgedogrulama.aspx?eD=BS56VZNCAL>
Tel : +90 (312) 218 20 00 (PBX) - Faks : +90 (312) 219 40 90 -91 -92... - E-Posta : info@tobb.org.tr
Bilgi İçin: İrem ARDIÇ - Tel : - E-Posta : irem.ardic@tobb.org.tr

Early Market Engagement Invitation Letter

Dear Sir or Madam,

The Ministry of Agriculture and Forestry has received financing from the World Bank toward the cost of the “Türkiye Climate Resilient Forests Project”, and intends to apply part of the proceeds toward payments under the contract for “Procurement of Digital Radio Communication System”.

General Directorate of Forestry is planning the procurement of fixed radios, mobile radios, handheld radios, relays, duplexers, radio links, containers, solar energy and electrical groundings, and related services through “Procurement of Digital Radio Communication System” contract under “Türkiye Climate Resilient Forests Project”. Prior to finalizing the bidding documents, which will be conducted through Request for Bids (RFB) method with open-international market approach (international competitive bidding), the General Directorate of Forestry is conducting an Early Market Engagement (EME) to obtain non-binding technical feedback from the market.

You are kindly invited to review the attached preliminary draft bidding document and to complete the attached EME Survey. This EME is not a procurement or prequalification procedure, and does not create any commitment or advantage.

The goal of EME is to:

- Communicate needs or requirements of Projects to interested firms;
- Openly and transparently discuss possible solutions;
- Collect feedback on determination of bidder` qualification criteria,
- Determine strategy on packaging of procurements
- Understand market capacity, capability and trends, and contractors` qualification.

On 03 July 2026 from 15:00 to 17:00 hrs (Istanbul time), the Project Implementation Unit will also arrange a virtual EME webinar event. Before joining the virtual meeting, interested firms are required to complete the registration by 02 July 2026, at 17:00 hrs (Istanbul time) for the Early Market Engagement webinar event.

The link for registration is:

<https://forms.gle/sru5UmrnXUTcVse27>

The connection information/link to the EME webinar event will be sent to the e-mail address included in the registration form.

The interested firms are required to fill out the attached questionnaires (EME Survey) in Annex II. The filled-out questionnaires are to be submitted by email to idop@ogm.gov.tr no later than 10 July 2026, 18.00 hrs (Istanbul time).

All responses received will be reviewed carefully, and the feedback will be analyzed collectively to determine whether any adjustments are needed to the bidding documentation before finalization.

Participation in the EME is voluntary and does not affect eligibility to participate in the future tender. Feedback provided will be considered internally by the Employer and the World Bank and will not be disclosed publicly or to other competitors.

Yours sincerely,

General Directorate of Forestry

Annex-I - Early Market Engagement Procedural Details

Annex II – EME Survey

Annex-I - Early Market Engagement Procedural Details

1. Introduction

In alignment with the World Bank's guidance on Early Market Engagement (EME) before the procurement process, this document outlines the procedural details for Early Market Engagement (EME) to be conducted prior to launching the bidding process. The purpose of EME is to engage proactively with the market at an early stage of procurement planning, before finalization and issuance of the bidding documents, in order to enhance market readiness, improve procurement outcomes, and ensure that the proposed procurement approach is realistic, competitive, and fit for purpose.

Early Market Engagement will be undertaken during the pre-procurement phase and will not constitute a commitment to procure, nor confer any advantage to any potential bidder. All engagement activities will be conducted in a transparent, non-discriminatory, and well-documented manner, consistent with the World Bank's core procurement principles.

The objectives of market engagement are to:

- Obtain market intelligence on capacity, interest, and potential risks associated with the proposed procurement.
- Test the feasibility and clarity of the proposed technical specifications and qualification requirements,
- Encourage broad national and international competition and enhance market awareness of the upcoming opportunity
- Ensure transparency and fairness in the procurement process.
- Gather valuable insights from potential bidders before publishing Specific Procurement Notice (SPN) and incorporate reasonable feedback for further improvement of the bidding documents.
- Ensure all potential bidders are fully informed and able to submit competitive, high-quality proposals.

2. Early Market Engagement Process (Pre-Bidding Phase):

2.1. Disclosure of Preliminary Draft Bidding Documents for Early Market Engagement

The invitation to EME along with the preliminary draft bidding documents (read only version) will be published and disclosed on the General Directorate of Forestry' website: <https://www.ogm.gov.tr/idop> for the purpose of Early Market Engagement.

The documents disclosed are intended solely for market consultation purposes and do not constitute an invitation to bid.

2.2. Targeted and Open Market Outreach:

In addition to being published on the General Directorate of Forestry' website, the invitation to EME will also be sent directly to known suppliers and manufacturers in the national and international markets. In order to enhance international outreach, the draft bidding documents will also be transmitted through Türkiye's overseas commercial counsellors and trade attachés, with a request to circulate them among relevant firms in their respective jurisdictions.

3. Solicitation of Structured Market Feedback

All interested market participants are invited to provide written feedback using a structured EME Survey. Feedback will be requested in particular on:

- clarity and feasibility of the technical specifications;
- appropriateness of qualification and evaluation criteria;
- contract structure, risk allocation, and implementation timelines; and
- any material market constraints or risks that may affect competition or performance.

4. Use of Market Feedback

All feedback received through the Early Market Engagement process will be systematically reviewed and analyzed by the Employer. Where considered reasonable and consistent with the World Bank's Procurement Regulations, feedback will be used to:

- refine and revise the preliminary draft bidding documents;
- confirm or adjust the proposed procurement approach;
- inform risk assessment and mitigation measures; and

5. Transition to Bidding Phase

Upon completion of Early Market Engagement, the Employer will finalize the bidding documents and proceed with the formal procurement process in accordance with the World Bank's Procurement Regulations. A clear separation will be maintained between the EME phase and the bidding phase to preserve fairness, transparency, and integrity of the competition.

Annex II – EME Survey**Section A – Company Information**

Company Name	
Country of Registration	
Address of company:	
Name of contact person of company:	
Email address of contact person:	

Section B - Supply and/or manufacturing experience**B1 - Which items can you manufacture and/or supply?**

(Select all that apply)

 Fixed Radio: Manufacturer SupplierYears experience: <5, 5–10, >10

For Supplier: Highest quantity under single contract during last 10 years (units): _____

For Manufacturer: Current annual production capacity (units per year): _____

 Mobile Radio: Manufacturer SupplierYears experience <5, 5–10, >10

For Supplier: Highest quantity under single contract during last 10 years (units): _____

For Manufacturer: Current annual production capacity (units per year): _____

 Handheld Radio: Manufacturer SupplierYears experience <5, 5–10, >10

For Supplier: Highest quantity under single contract during last 10 years (units): _____

For Manufacturer: Current annual production capacity (units per year): _____

 Relay: Manufacturer SupplierYears experience <5, 5–10, >10

For Supplier: Highest quantity under single contract during last 10 years (units): _____

For Manufacturer: Current annual production capacity (units per year): _____

 Duplexer: Manufacturer SupplierYears experience <5, 5–10, >10

For Supplier: Highest quantity under single contract during last 10 years (units): _____

For Manufacturer: Current annual production capacity (units per year): _____

 Radio link:

Manufacturer Supplier

Years experience <5, 5–10, >10

For Supplier: Highest quantity under single contract during last 10 years (units): _____

For Manufacturer: Current annual production capacity (units per year): _____

Container:

Manufacturer Supplier

Years experience <5, 5–10, >10

For Supplier: Highest quantity under single contract during last 10 years (units): _____

For Manufacturer: Current annual production capacity (units per year): _____

Solar Energy:

Manufacturer Supplier

Years experience <5, 5–10, >10

For Supplier: Highest quantity under single contract during last 10 years (units): _____

For Manufacturer: Current annual production capacity (units per year): _____

Electrical Grounding:

Manufacturer Supplier

Years experience <5, 5–10, >10

For Supplier: Highest quantity under single contract during last 10 years (units): _____

For Manufacturer: Current annual production capacity (units per year): _____

Section C - Tender Packaging Options

Which one of the following packaging option do you prefer? Select all that apply:

Option 1	Option 2	Option 3	Option 4 <i>Please provide your packaging suggestion</i>
<p>Tender Package-1 <i>(bidders must bid for all items in the package)</i></p> <p>Fixed Radio Mobile Radio Handheld Radio Relay Duplexer Radio link Container Solar Energy Electrical Grounding</p>	<p>Tender Package 1 <i>(bidders must bid for all items in the package)</i></p> <p>Fixed Radio Mobile Radio Handheld Radio Relay Duplexer Radio link</p> <p>Tender Package 2 <i>(bidders must bid for all items in the package)</i></p> <p>Container Solar Energy Electrical Grounding</p>	<p>Tender Package 1 <i>(bidders may bid for any one or more Lots)</i></p> <p><input type="checkbox"/> Lot 1: Fixed Radio Mobile Radio Handheld Radio Relay</p> <p>Lot 2: Duplexer</p> <p>Lot 3: Radio link</p> <p>Tender Package 2 Container Solar Energy Electrical Grounding</p>	

Section E – Delivery Timelines

E1. Envisaged delivery period from contract signature (months):

<u>Item Type</u>	<u>Select all that apply</u>
Fixed Radio	<input type="checkbox"/> <12 <input type="checkbox"/> 12–20 <input type="checkbox"/> 20–30 <input type="checkbox"/> ___ (Please specify if more than 30 months)
Mobile Radio	<input type="checkbox"/> <12 <input type="checkbox"/> 12–20 <input type="checkbox"/> 20–30 <input type="checkbox"/> ___ (Please specify if more than 30 months)
Handheld Radio	<input type="checkbox"/> <12 <input type="checkbox"/> 12–20 <input type="checkbox"/> 20–30 <input type="checkbox"/> ___ (Please specify if more than 30 months)
Relay	<input type="checkbox"/> <12 <input type="checkbox"/> 12–20 <input type="checkbox"/> 20–30 <input type="checkbox"/> ___ (Please specify if more than 30 months)
Duplexer	<input type="checkbox"/> <12 <input type="checkbox"/> 12–20 <input type="checkbox"/> 20–30 <input type="checkbox"/> ___ (Please specify if more than 30 months)
Radio link	<input type="checkbox"/> <12 <input type="checkbox"/> 12–20 <input type="checkbox"/> 20–30 <input type="checkbox"/> ___ (Please specify if more than 30 months)
Container	<input type="checkbox"/> <12 <input type="checkbox"/> 12–20 <input type="checkbox"/> 20–30 <input type="checkbox"/> ___ (Please specify if more than 30 months)
Solar Energy	<input type="checkbox"/> <12 <input type="checkbox"/> 12–20 <input type="checkbox"/> 20–30 <input type="checkbox"/> ___ (Please specify if more than 30 months)
Electrical Grounding	<input type="checkbox"/> <12 <input type="checkbox"/> 12–20 <input type="checkbox"/> 20–30 <input type="checkbox"/> ___ (Please specify if more than 30 months)

E2. Key factors influencing delivery timelines:

- Manufacturing capacity
 Customization of manufacturing
 Testing and certification
 Logistics
 Other: _____

Section F – After-Sales Support**F1. After-sales support in Türkiye:**

<u>Item Type</u>	<u>Select all that apply</u>
Fixed Radio	<input type="checkbox"/> Directly by manufacturer <input type="checkbox"/> Through local partner <input type="checkbox"/> Not available
Mobile Radio	<input type="checkbox"/> Directly by manufacturer <input type="checkbox"/> Through local partner <input type="checkbox"/> Not available
Handheld Radio	<input type="checkbox"/> Directly by manufacturer <input type="checkbox"/> Through local partner <input type="checkbox"/> Not available
Relay	<input type="checkbox"/> Directly by manufacturer <input type="checkbox"/> Through local partner <input type="checkbox"/> Not available
Duplexer	<input type="checkbox"/> Directly by manufacturer <input type="checkbox"/> Through local partner <input type="checkbox"/> Not available
Radio link	<input type="checkbox"/> Directly by manufacturer <input type="checkbox"/> Through local partner <input type="checkbox"/> Not available
Solar Energy	<input type="checkbox"/> Directly by manufacturer <input type="checkbox"/> Through local partner <input type="checkbox"/> Not available
Container	<input type="checkbox"/> Directly by manufacturer <input type="checkbox"/> Through local partner <input type="checkbox"/> Not available

F2. Spare parts availability period:

- Fixed Radio 5 years 5-10 years >10 years
Mobile Radio 5 years 5-10 years >10 years
Handheld Radio 5 years 5-10 years >10 years
Relay 5 years 5-10 years >10 years
Duplexer 5 years 5-10 years >10 years

Radio link 5 years 5-10 years >10 years
Solar Energy 5 years 5-10 years >10 years
Container 5 years 5-10 years >10 years

Section G – Market/Technical Specification Feedback

Section	Question	Answer Options	Your Explanation or Suggestion
1. Technical Specifications	Are the technical specifications clear and understandable?	<input type="checkbox"/> Yes <input type="checkbox"/> No	
	Are the Items' technical requirements feasible in practice?	<input type="checkbox"/> Yes <input type="checkbox"/> No	
	Are there any risks or shortcomings related to the components/parts of the items	<input type="checkbox"/> Yes <input type="checkbox"/> No	
2. Qualification and Experience Criteria	Please provide feedback if any of the qualification criteria in Section-III of the bidding document need improvement or clarification?		
3. Rated Criteria and Weightings	Are the rated criteria provided in Section III of the bidding document clear and understandable?	<input type="checkbox"/> Yes <input type="checkbox"/> No	
	Please provide feedback and suggestions for the factors/sub factor/range/weightings provided in Section III to be used as the rated criteria.		

Section	Question	Answer Options	Your Explanation or Suggestion
4. Bidding Document	Are there any contradictory, missing, or hard-to-understand Sections in the document?	<input type="checkbox"/> Yes <input type="checkbox"/> No	
	Would you recommend any improvements or additions to the document?	<input type="checkbox"/> Yes <input type="checkbox"/> No	

*For more detailed points you wish to specify, please use the table below:

No	Document Name/ Section / Clause No	Current Provision	Identified Issue / Market Relevance	Proposed Change/ Explanation	Priority/ (High/Medium/low)
1					
2					
3					

Section III - Evaluation and Qualification Criteria

This Section contains the criteria that the Purchaser shall use to evaluate Bids and qualify the Bidders. No other factors, methods or criteria shall be used other than specified in this bidding document.

TECHNICAL PART

1. Qualification

Qualification Criteria (ITB 32.1)

The qualification criteria below are provided for purpose of indication against the corresponding indicative contracts/items. Subject to feedback received through the Early Market Engagement (EME) survey, similar items may be consolidated into lots comprising related items, and the applicable qualification criteria will apply accordingly. Relevant qualification criteria that is applicable for respective lots will be rearranged at the bidding stage.

The Purchaser shall assess each Bid against the following Qualification Criteria. Requirements not included in the text below shall not be used in the evaluation of the Bidder's qualifications.

- (a) **Financial Capability:** The Bidder shall submit audited financial statements or, if not required by the law of the Bidder's country, other financial statements acceptable to the Purchaser, for the last three years (2023-2024-2025) prior to bid submission deadline, demonstrating the current soundness of the Bidder's financial position **and indicate its prospective long-term profitability**. For a joint venture, this requirement shall be met by each member;
- (b) **Specific Experience:** The Bidder shall demonstrate that it has successfully completed at least two contracts of a similar nature and complexity to the Goods and Related Services under the proposed contract/item, each meeting the minimum contract value indicated below for the respective item within the last 10 (ten) years prior to the bid submission deadline (from January 1, 2016, to the bid submission deadline). For a joint venture, this requirement may be met by all members combined.

The similar experience requirements and the nature of similar works for each item are as follows:

Items	The Similar Experience Requirement for single contract (USD)	Nature of Similar Works
Fixed Radio	1.8 million	Manufacture and/or supply of radio (handheld and/or fixed and/or mobile terminals and/or relay networks), or manufacture and/or supply and installation of radio links and/or supply and installation of land mobile systems including digital communication systems.
Mobile Radio	2.55 million	Manufacture and/or supply of radio (handheld and/or fixed and/or mobile terminals and/or relay networks), or manufacture and/or supply and installation of radio links and/or supply and installation of land mobile systems including digital communication systems.
Handheld Radio	4.5 million	Manufacture and/or supply of radio (handheld and/or fixed and/or mobile terminals and/or relay networks), or manufacture and/or supply and installation of radio links and/or supply and installation of land mobile systems including digital communication systems.
Relay	2.6 million	Manufacture and/or supply and installation of radio links and/or supply and installation of land mobile systems including relay for digital communication systems.

Duplexer	750,000	Manufacture and/or supply and installation of radio links and/or supply and installation of land mobile systems dublexer for digital communication systems.
Radio link	3.65 million	Manufacture and/or supply and installation of radio links and/or supply and installation of land mobile systems including digital communication systems.
Container	2.0 million	Manufacture and/or supply of containers
Solar Energy	1.75 million	Manufacture and/or supply of solar energy
Electrical Grounding	500 thousand	Supply and installation of electrical grounding for digital communication systems.

- (c) **Documentary Evidence:** The Bidder shall furnish documentary evidence to demonstrate that the Goods it offers meet the usage requirements in the Critical Technical Specifications Summary Table provided in Section VII – Technical Specifications of this bidding document.
- (d) **Manufacturing experience and Technical Capacity:** For the items under the Contract that the bidder is a manufacturer, the Bidder shall furnish documentary evidence to demonstrate that the manufacturer of the offered goods:
- (i) it has manufactured goods of similar nature and complexity for at least 3 (three) years prior to the bid submission deadline; and

(ii) its annual production capacity of goods of similar nature and complexity for each of the last 3 (three)(2023-2024-2025) years prior to the bid submission deadline, is at least two times of the quantities specified under the contract.

(e) **Manufacturer’s authorization:** A Bidder who does not manufacture an item/s where a manufacturer authorization is required in accordance with BDS ITB 17.2 (a), the Bidder shall provide evidence of being duly authorized by a manufacturer (Manufacturer’s Authorization Form, Section IV, Bidding Forms), meeting the criteria in (d) (i) and (ii) above, to supply the Goods;

(f) A Bidder who does not manufacture an item/s where a manufacturer authorization is not required in accordance with BDS ITB 17.2 (a), the bidder shall submit documentation on its status as a supplier, to the satisfaction of the Purchaser

At the time of Contract Award, the Bidder (including each subcontractor proposed by the Bidder) shall not be subject to disqualification by the Bank for non-compliance with SEA/ SH obligations.

2. Technical Evaluation (ITB 32.4)

Assessment of adequacy of Technical Part with the requirements

Minimum technical requirements are provided within the Critical Technical Specifications Summary Table in Section-VII, Technical Specifications of this bidding document. Those minimum requirements have to be met by the technical part prior to being considered for technical evaluation by applying the scored technical factors.

Technical Part Scoring Methodology

The rated criteria below are indicative at the Early Market Engagement (EME) stage. Subject to feedback received through the EME survey, certain items may be consolidated under lots with similar items, and the applicable rated criteria will apply to each lot accordingly.

Relevant rated criteria that is applicable for respective lots will be rearranged. During the bidding process, bids will be evaluated against the rated criteria applicable to each respective lot.

A) IP Protection Class Levels (25%)

Handheld, fixed, and mobile radios shall have a minimum IP54 protection rating.

Score (of the total score for the factor/subfactor as applicable	Description
--	-------------

1 (25%)	has IP 54 protection rating
2 (50%)	has IP 55 to IP65 protection rating
3 (75%)	has IP 66 to IP 67 protection rating
4 (100%)	has better than IP 67 protection rating

B. Battery Capacity (20%)

Batteries for handheld radios shall have a capacity of at least 1900 mAh.

Score (of the total score for the factor/subfactor as applicable)	Description
1 (25%)	1900-2199 mAh
2 (50%)	2200-2499 mAh
3 (75%)	2500 mAh and 2999 mAh
4 (100%)	3000 mAh and above

C. Minimum Receiver Sensitivity (%25)

The handheld radios shall have a receiver sensitivity of minimum 0.40 μ V for 12 dB SINAD in analog mode.

Score (of the total score for the factor/subfactor as applicable)	Description
1 (25%)	has receiver sensitivity of 0.40 μ V and 0.35 μ V in analog mode.
2 (50%)	has receiver sensitivity of 0.349 μ V and 0.3 μ V in analog mode.
3 (75%)	has receiver sensitivity of 0.299 μ V and 0.2 μ V in analog mode.
4 (100%)	has receiver sensitivity of 0.2 μ V and 0.18 μ V in analog mode.

D. Duplexer Signal Attenuation Rate (%15)

The signal attenuation rate of the bandpass part shall be at most -2 dB

Score (of the total score for the factor/subfactor as applicable)	Description
1 (25%)	-2 dB to -1.6 dB
2 (50%)	-1.5 dB to -1.1dB
3 (100%)	-1 dB and below

C. Duplexer Signal Suppression Rate (%15)

The signal suppression rate of the band stop part will be at most -80 dB

Score (of the total score for the factor/subfactor as applicable)	Description
1 (25%)	-80 dB to -84 dB
2 (50%)	-85 dB to -89 dB
3 (100%)	-90 dB and above

Score (of the total score for the factor/subfactor as applicable)	Description	Remarks
0	Required feature is absent; no relevant information to demonstrate how the requirement is met	
1	Required feature present with deficiencies such as insufficient or information that lacks clarity	
2	Sufficient information to demonstrate how the requirement will be met	
3	Sufficient information to demonstrate that the requirement will be marginally exceeded	
4	Sufficient information that significantly exceed the requirement/bid contributes to significant value addition	

The score for each sub- factor (i) within a factor (j) will be combined with the scores of sub- factors in *the* same factor as a weighted sum to form the Factor Technical Score using the following formula:

$$S_j \equiv \sum_{i=1}^k t_{ji} * w_{ji}$$

where:

t_{ji} = the technical score for sub- factor “i” in factor “j”,

w_{ji} = the weight of sub- factor “i” in factor “j”,

k = the number of scored sub-factors in factor “j”, and

$$\sum_{i=1}^k w_{ji} = 1$$

The Factor Technical Scores will be combined in a weighted sum to form the total Technical Bid Score using the following formula:

$$T \equiv \sum_{j=1}^n S_j * W_j$$

where:

S_j = the Factor Technical Score of factor “j”,

W_j = the weight of factor “j” as specified **in the BDS**,

n = the number of Factors, and

$$\sum_{j=1}^n W_j = 1$$

Draft Document

FINANCIAL PART

1. Margin of Preference (ITB 37)

Margin of Preference shall not apply.

2. Evaluation Criteria (ITB 34.6)

The Purchaser shall use the criteria and methodologies listed in this Section to evaluate the Financial Part.

The Purchaser's evaluation of the Financial Part may take into account, in addition to the Bid Price, one or more of the following factors as **specified in BDS ITB 34.6**, using the following criteria and methodologies.

- (a) Delivery schedule. (As per Incoterms specified in the BDS) Not Applicable
- (b) Deviation in payment schedule. Not Applicable
- (c) Cost of major replacement components, mandatory spare parts, and service. Not Applicable
- (d) Availability in the Purchaser's Country of spare parts and after sales services for equipment offered in the Bid. Not Applicable
- (e) Life Cycle Cost . Not Applicable
- (f) Performance and productivity of the equipment. Not Applicable
- (g) Specific additional criteria . Not Applicable

Combined Evaluation

The Purchaser will evaluate and compare the Bids that have been determined to be substantially responsive.

The Purchaser's evaluation of responsive Bids will take into account technical factors, in addition to cost factors.

An Evaluated Bid Score (B) will be calculated for each responsive Bid using the following formula (for comparison in percentages), which permits a comprehensive assessment of the Bid price and the technical merits of each Bid:

$$B \equiv \frac{C_{low}}{C} * X * 100 + \frac{T}{T_{high}} * (1 - X) * 100$$

where

C = Evaluated Bid Price

C_{low} = the lowest of all Evaluated Bid Prices among responsive Bids

T = the total Technical Score awarded to the Bid

T_{high} = the Technical Score achieved by the Bid that was scored best among all responsive Bids

X = weight for the Cost as specified in the BDS

The Bid with the best evaluated Bid Score (B) among responsive Bids shall be the Most Advantageous Bid provided the Bidder is qualified to perform the Contract.

Multiple Contracts (ITB 34.4) Not Applicable

If in accordance with **ITB 1.1**, Bids are invited for more than one lot, the contract will be awarded to the Bidder or Bidders with the Most Advantageous Bid for the individual lots.

However, if a Bidder, with Bids that are substantially responsive and with highest evaluated score for individual lots, is not qualified for the combination of the lots, then the award will be made based on the highest total score for combination of lots for which Bidders are qualified.

Alternative Bids (ITB 13.1) Not Applicable

Section VII - Schedule of Requirements

Contents

1. List of Goods and Delivery Schedule	12
2. List of Related Services and Completion Schedule.....	14
3. Technical Specifications	16
4. Drawings	55
5. Inspections and Tests.....	57

Draft Document

1. List of Goods and Delivery Schedule

1.1 List of Goods and Delivery Schedule

Line Item N°	Description of Goods	Quantity	Physical unit	Final (Project Site) Destination as specified in BDS	Delivery (as per Incoterms) Date		
					Earliest Delivery Date	Latest Delivery Date	Bidder's offered Delivery date [<i>to be provided by the Bidder</i>]
1	Radio link	150		Muğla Antalya Mersin Adana Hatay K.Maraş Regional Directorates of Forestry	Within 8 months following the effectiveness of the Contract	Within 12 months following the effectiveness of the Contract	
2	Container	100					
3	Solar Energy	101					
4	Electrical Grounding	118					

1.2 List of Goods and Delivery Schedule

Line Item N°	Description of Goods	Quantity	Physical unit	Final (Project Site) Destination as specified in BDS	Delivery (as per Incoterms) Date		
					Earliest Delivery Date	Latest Delivery Date	Bidder's offered Delivery date [<i>to be provided by the Bidder</i>]
1	Radio link	190		Çanakkale, Balıkesir, İzmir Regional Directorates of Forestry	Within 8 months following the delivery of goods listed in Table 1.1 above	Within 12 months following the delivery of goods listed in Table 1.1 above	
2	Container	155					
3	Solar Energy	142					
--4	Electrical Grounding	181					

1.3 List of Goods and Delivery Schedule

Line Item N°	Description of Goods	Quantity	Physical unit	Final (Project Site) Destination as specified in BDS	Delivery (as per Incoterms) Date		
					Earliest Delivery Date	Latest Delivery Date	Bidder's offered Delivery date [<i>to be provided by the Bidder</i>]
1	Fixed Radio	1500		Çanakkale, Balıkesir, İzmir, Muğla Antalya Mersin Adana Hatay K.Maraş Regional Directorates of Forestry	Within 20 months following the effectiveness of the Contract	Within 30 months following the effectiveness of the Contract	
2	Mobile Radio	2600					
3	Handheld Radio	5500					
4	Relay	350					
5	Duplexer	350					

1. List of Related Services and Completion Schedule

[This table shall be filled in by the Purchaser. The Required Completion Dates should be realistic, and consistent with the required Goods Delivery Dates (as per Incoterms)]

Service	Description of Service	Quantity	Physical Unit	Place where Services shall be performed	Final Completion Date(s) of Services
<i>1</i>	Installation works	<i>[insert quantity of items to be supplied]</i>	<i>[insert physical unit for the items]</i>	The coordinates specified in Appendix 1	<i>30 months</i>
2	Construction works			The coordinates specified in Appendix 1	<i>30 months</i>
3	Software			The coordinates specified in Appendix 1	<i>30 months</i>

3. Technical Specifications

CLIMATE RESILIENT FORESTS PROJECT TECHNICAL SPECIFICATIONS OF DIGITAL RADIO COMMUNICATION SYSTEM

1. SUBJECT

This technical specification includes digital radio devices (handheld, mobile, fixed, relay, duplexer) that can operate both digital and analog in the 34-36 MHz band, radio link, container, solar energy, camera, electrical grounding installation, technical specifications and other relevant issues related to the necessary software, hardware equipment and other materials to be purchased for the needs of the General Directorate of Forestry. The digital radio communication system to be established in the Çanakkale, Balıkesir, İzmir, Muğla, Antalya, Mersin, Adana, Hatay, and Kahramanmaraş Regional Directorates of Forestry will operate in a manner compatible with the existing radio communication system in the Forest Regional Directorates.

2. CONTEXT

2.1. A digital radio communication system specified below and to be installed by the Supplier covers mounted and unmounted devices.

TYPE	QUANTITY (ADET)	DESCRIPTION
Fixed Radio	1500	Will be delivered to the Çanakkale, Balıkesir, İzmir, Muğla, Antalya, Mersin, Adana, Hatay, and Kahramanmaraş Regional Directorates of Forestry. Installations of the fixed radio terminals will be carried out by the Purchaser.
Mobile Radio	2600	Will be delivered to the Çanakkale, Balıkesir, İzmir, Muğla, Antalya, Mersin, Adana, Hatay, and Kahramanmaraş Regional Directorates of Forestry. . Installations of the mobile radio terminals will be carried out by the Purchaser.
Handheld Radio	5500	Will be delivered to the Çanakkale, Balıkesir, İzmir, Muğla, Antalya, Mersin, Adana, Hatay, and Kahramanmaraş Regional Directorates of Forestry.
Relay	350	The installation of relays shall be carried out by the Supplier at the Fire Observation Towers/Towers within the boundaries of the Balıkesir, İzmir, Muğla, Antalya, Mersin, Adana, Hatay, and Kahramanmaraş Regional Directorates of Forestry, as specified in the technical specifications and to be supplied by the Supplier, or at the facility/facilities designated by the Purchaser. A total of 9 servers and 9 notebooks will be provided along with the relay. (38 relays will be delivered to the Purchaser for use as spares.)
Duplexer	350	Will be used in the 34-36 MHz band. (38 duplexers will be delivered to the Purchaser for use as spares.)

Radio link	340	Installation of radio links on a total of 680 poles, with two (2) poles provided for each radio link, each having a length of 10 or 12 meters as specified in the technical specifications and to be supplied by the Supplier, to the Fire Watch Tower/Towers, Lattice Antenna Towers/Towers, or containers within the boundaries of the Çanakkale, Balıkesir, İzmir, Muğla, Antalya, Mersin, Adana, Hatay, and Kahramanmaraş Regional Directorates of Forestry listed in the attached list. The operation of the radio link and relay device will be provided by the Supplier (installations of the internal units of the microwave system will be carried out inside the cabinet/rack system). Each radio link system consists of the following units. (28 radio links will be delivered to the Purchaser for use as spares.)			
		Indoor Unit (with at least 4-way fixed or removable modem)	Outdoor Unit (High or Low)	Antenna 60 cm	Antenna 90 cm
		1 pcs	3 pcs	2 pcs	1 pcs
Container	255	Installation will be carried out by the Supplier at locations specified by the Purchaser within the boundaries of the Çanakkale, Balıkesir, İzmir, Muğla, Antalya, Mersin, Adana, Hatay, and Kahramanmaraş Regional Directorates of Forestry listed in the appendix to this technical specification (Including Foundation Concrete and Physical Security Materials). The Supplier shall construct a total of 18 lattice antenna towers in accordance with Article 10 of the technical specifications, the locations of which shall be determined by the Purchaser, and shall provide a total of 78 cabinets in accordance with Article 6 of the technical specifications.			
Solar Energy	243	The installation of the fixed solar energy system will be carried out by the Supplier at the Fire Observation Tower/Towers or containers located within the boundaries of the Çanakkale, Balıkesir, İzmir, Muğla, Antalya, Mersin, Adana, Hatay, and Kahramanmaraş Regional Directorates of Forestry listed in the appendix to this technical specification, and the system will be connected to them.			
Electrical Grounding	299	Installation will be carried out by the Supplier at the Fire Observation Tower/Towers within the boundaries of the Çanakkale, Balıkesir, İzmir, Muğla, Antalya, Mersin, Adana, Hatay, and Kahramanmaraş Regional Directorates of Forestry listed in the appendix to this technical specification, or at the facility/facilities designated by the Purchaser.			

2.2. The infrastructure of the Digital Radio Communication System specified in Article 2.1 of this specification will be installed by the Supplier in Çanakkale, Balıkesir, İzmir, Muğla, Antalya, Mersin, Adana, Hatay and Kahramanmaraş Regional Directorate of Forestry in places determined by the Purchaser within the framework of a joint plan to be determined by the Supplier and the Purchaser

(Appendix 1 - Draft List of Locations Where Digital Radio Communication Systems Will Be Installed), and the devices to be installed will be delivered to the Purchaser in working condition.

2.3. Delivery schedule will be made in 3 phases; The lists below show the quantities of devices to be installed and assembled in the Çanakkale, Balıkesir, İzmir, Muğla, Antalya, Mersin, Adana, Hatay, and Kahramanmaraş Regional Directorates of Forestry. The lists may be amended if mutually agreed upon by the Supplier and the Purchaser.

1. Period: A list showing the number of devices to be installed and assembled in the Antalya, Muğla, Mersin, Adana, Kahramanmaraş, and Hatay Regional Directorates of Forestry

1st Period		Ç.KALE	B.ESİR	İZMİR	MUĞLA	ANTALYA	MERSİN	ADANA	HATAY	K.MARAŞ
TYPE	TOTAL	PCS	PCS	PCS	PCS	PCS	PCS	PCS	PCS	PCS
FIXED RADIO										
MOBILE RADIO										
HANDHELD RADIO										
RELAY										
DUBLEXER										
RADIO LINK	150				66	12	12	10	22	28
CONTAINER	100				49	2	2	2	20	25
SOLAR ENERGY	101				50	2	2	2	20	25
ELECTRICAL GORUNDING	118				65	2	2	2	20	27

2. Period: A list showing the number of devices to be installed and assembled at the Çanakkale, Balıkesir, İzmir Regional Directorates of Forestry

2nd Period		Ç.KALE	BALIKESİR	İZMİR	MUĞLA	ANTALYA	MERSİN	ADANA	HATAY	K.MARAŞ
TYPE	TOTAL	PCS	PCS	PCS	PCS	PCS	PCS	PCS	PCS	PCS
FIXED RADIO										
MOBILE RADIO										
HANDHELD RADIO										
RELAY										
DUBLEXER										
RADIO LINK	190	44	70	76						
CONTAINER	155	36	61	58						
SOLAR ENERGY	142	36	61	45						
ELECTRICAL GORUNDING	181	43	69	69						

3. Period: The Supplier shall install and commission the specified quantities of relays and duplexers at the Çanakkale, Balıkesir, İzmir, Muğla, Antalya, Mersin, Adana, Hatay, and Kahramanmaraş Regional Directorates of Forestry, handheld/mobile/fixed radios will be delivered to the Purchaser without installation.

3rd Period		Ç.KALE	B.ESİR	İZMİR	MUĞLA	ANTALYA	MERSİN	ADANA	HATAY	K.MARAŞ
TYPE	TOTAL	PCS	PCS	PCS	PCS	PCS	PCS	PCS	PCS	PCS
FIXED RADIO	1,500	150	150	250	200	200	200	200	50	100
MOBILE RADIO	2,600	300	350	350	400	350	250	250	150	200
HANDHELD RADIO	5,500	400	550	1000	1,000	800	500	600	300	350
RELAY	350	44	70	76	66	15	15	14	22	28
DUBLEXER	350	44	70	76	66	15	15	14	22	28
RADIO LINK										
CONTAINER										
SOLAR ENERGY										
ELECTRICAL GORUNDING										

2.4. The equipment that constitutes the digital radio communication system, intra-cell and inter-cell communication will be capable of meeting the needs of the Purchaser.

2.5. The software and hardware required to manage the system will be covered by the Supplier.

2.6. The table in this article and the "responses to the technical specification document" required in Article 7 of the administrative specification will be filled in completely and more than one product will not be offered.

2.7. Since the technical documents (catalogs, prospectuses, etc.) of the offered products and the answers to the technical specifications will be considered in the technical examination of the offers the technical values contained in these documents and the answers to the technical specifications will be compatible with each other. However, in case of incompatibility between these, technical documents will be respected.

3. RADIO SYSTEM FEATURES

3.1. General Characteristics

3.1.1. The radios shall be capable of both digital and analog communication, with the ability to switch between analog and digital modes at the push of a button. They shall operate in analog mode alongside the Purchaser's existing digital-analog radios.

3.1.2. Digital groups and analog channels can be programmed together in handheld, mobile, fixed and relay radios, and it will be possible to make digital calls and analog calls between radios when desired.

3.1.3. All devices and materials to be supplied will be of standard production and unused.

3.1.4. A label on the devices will include the model and serial number of the device.

3.1.5. The devices will be CE marked.

3.1.6. All accessories and apparatus required for the devices to meet the features specified in the technical specifications will be provided with the device.

3.1.7. The system will be delivered turn-key and in working condition. If there are extra materials-parts not specified in this specification for the operation of the system and any consumables needed during installation, these will be covered by the Supplier without any additional fee.

3.1.8. Radio devices shall comply with the "Radio Equipment Regulation" of the Information and Communication Technologies Authority and the (ETSI) ETS 300 086, ETS 300 113 standards, and a European Union CE standard compliance declaration certificate will be provided for each radio device during the delivery/installation phase. The Purchaser will request a certificate from the Information and Communication Technologies Authority regarding the radio device(s)' compliance with technical regulations. Any costs incurred for this process shall be borne by the Supplier.

3.1.9. During the network setup phase, "network introduction, maintenance, and support training" will be provided. Following the installation/setup of the devices, both "user training" and "supervisor/instructor training" will be conducted. Training will be repeated if deemed appropriate by the Purchaser, and new training will be provided if a new version feature is added to the system. The Supplier will issue certificates to personnel at the end of the training confirming their participation.

3.1.10. For cable connections, suitable connectors from the following brands will be used: Amphenol, Rosenberger, Telegärtner, Huber + Suhner, Spinner, Bracke, RFS, Andrew, Gigalane, Dynawave, and A-Info.

3.2. Tele Service

3.2.1. Private Individual Call: In digital mode, an authorized device can call another device. The conversation takes place only between these two radios; other radios cannot answer, listen or join the conversation.

3.2.2. After group voice calls have started, new radios joining the call will be able to listen to the call from the point at which they joined.

3.2.3. The proposed system will be capable of handling at least two simultaneous voice calls.

3.2.4. Calls can be terminated from the authorized terminal. The authorized terminal will have transmission priority by interrupting the call it is listening to.

3.2.5. Measures will be taken to prevent interference between radio calls during communication via repeaters on non-system digital channels. If multiple radios press the talk button simultaneously, one radio will be granted permission to speak and will send an audio call. A warning will appear on the other radios indicating that another radio has been granted push-to-talk permission.

3.3. Supplementary Services

3.3.1. Voice Telephone Interconnect: If an authorized radio device is used via IPBX and PABX gateway, it will be able to initiate a call to any telephone subscriber by connecting to the telephone network (PABX). If the communication between telephone and wireless subscribers is programmed in this way, it will be half-duplex.

3.3.2. Talking Party Identification: During a group call in digital mode; The identification number of the radio that switches to transmit during a channel call in analog mode will appear on the screen of the radios that come to the traffic channel for this call.

3.3.3. Call Alerting or Missed Called List: For an individual call that is not answered when the radio device is on in digital mode; It will keep the identification number of the calling radio as a call alert.

3.3.4. The radios will automatically calculate the parameters specified to register to the relay. According to these parameters, the radio will be connected to the relay that receives the signal at the highest power level and lowest noise level. Radios will automatically be registered to different relays according to changing power and noise levels while in motion.

3.3.5. All radios in the same group will have a group call feature so that they can communicate quickly, regardless of their location in the network. Group calls can be initiated both on a business basis and on an entire region basis. In the system, priority should be defined for specified groups, programmed devices and users.

3.3.6. Radio devices can be programmed as both group calls and zone calls in digital mode.

3.3.7. The relay will have IPV4 standard to ensure system integrity. IPV4 addresses will be determined by the Purchaser.

3.3.8. When a group call is initiated in digital mode, if there is no conversation, the relay will end the call after a certain period of time to avoid occupying the slot. This time can be adjusted via the relay.

3.3.9. In digital mode, relays to be installed in the region will be able to operate synchronously and smoothly.

3.4. System General Services

3.4.1. Registration: The radio device will be registered to the system in order to receive service from the system.

3.4.2. Group Affiliation: The radio device will be registered in the system for the group it wants to talk to.

3.4.3. Registration between Regional Directorates: Radio devices will have the feature of switching between regional directorates via gateway or directly in digital mode and will be able to communicate directly.

3.5. System Numbering and Frequency Plan

3.5.1. Radio devices will be programmed with an identification number of up to 5 in analog mode and up to 7 in digital mode. The number of the calling radio will be seen on the screen of the other radio or radios (except the relay).

3.5.2. In analog mode, transceiver frequencies, tone frequencies, channel names and ID numbers will be notified by the Purchaser after the contract. The devices will be delivered to the Purchaser to include these features. The Purchaser will be able to use all the channel capacities in the catalogs of the radios.

3.5.3. In digital mode, business groups, their names, numbers and ID numbers will be notified to the Supplier by the Purchaser after the contract. In digital mode, the frequency plan will cover the entire digital band. Radio devices will operate by scanning in this band range.

3.6. General Characteristics of Radio Devices

3.6.1. Handheld, mobile, fixed radios and relay will operate in the 34-36 MHz frequency band of the VHF band. The frequencies to be used and other details will be notified to the Supplier later by the Purchaser.

3.6.2. Channel spacing will be 12.5 KHz.

3.6.3. The modulation will be 11KOF3E in analog mode.

3.6.4. The channel and group capacities of the radio devices to be received will be at least as follows:

3.6.4.1. Handheld, mobile and fixed radios will be programmable for at least 1000 channels in analog mode, and the relay will be programmable for at least 16 channels.

3.6.4.2. Handheld, mobile, and fixed radios will be programmable for at least 500 channels in digital mode, and the repeater will be programmable for at least 16 channels.

3.6.5. All radios, except for the relays, will operate in half-duplex and simplex modes in analog mode. Additionally, all radios, except for the relays, will be capable of conducting digital simplex voice communications in digital mode—without a digital relay connection—within a frequency range designated by the authority and among designated users, similar to analog radios.

3.6.6. In half-duplex operating mode, the frequency separation between transmitter and receiver will be 500 KHz.

3.6.7. There will be an illuminated alphanumeric display and keypad on the handheld radio. Mobile and fixed radios will have an illuminated alphanumeric screen and/or keypad on the hand terminal. When necessary, shortcut assignments can be made to the keypads on the radios.

3.6.8. The brightness of the screen and/or keypads can be adjusted by the user.

3.6.9. The operating temperature range of the radios will be between at least -15°C and 55°C.

3.6.10. Radios (except relay) will have relay select mode in digital mode. When this mode is switched, it will be possible to connect to the desired relay manually.

3.6.11. Radios (excluding the relay) will be able to view the connection levels of other relays in the relevant mode from the radio menu, even if they are registered to a relay in digital mode.

3.6.12. The display of the radios (excluding the repeater) will show icons indicating the received signal level, transmitter signal level, the repeater where it is registered in digital mode, the name of the operator, and the channel number in analog mode, etc. The speaker volume level will be displayed on the screen.

3.6.13. Radios will have a timing circuit that limits the transmit time. This sending time can be adjusted.

3.6.14. Transmitter output and receiver input RF impedance must be 50 ohms.

3.6.15. Transmitter Features: The output power of handheld radios is 5 watts; the output power of mobile and fixed radios is 25 watts; and the output power of relays is 50 watts.

3.6.16. All radio devices will be capable of CTCSS (multitone) tone programming in analog mode.

3.6.17. Necessary precautions will be taken to prevent any malfunction in case of antenna incompatibility or excessive transmitter temperature in radios.

3.6.18. If the number of channels of the radios (handheld, mobile and fixed) in analogue mode is over 500 channels, 900 channels of the radios used in 30 Regional Forestry Directorates can be named through the program. Radio devices will have an index feature.

3.6.19. The radios will be able to name groups of Forest Management Directorates affiliated to 30 Regional Forestry Directorates in digital mode and will have an index feature.

3.6.20. Radios (handheld, mobile and fixed) will have channel scanning feature in Analog mode.

3.6.21. Handheld, vehicle, and fixed radios will have an internal GPS module and will automatically transmit location information in digital mode. Coordinate information will also be visible via the radio in both digital and analog modes.

3.7. Technical Specifications of Handheld Radio Devices

3.7.1. All parts and batteries of a handheld radio will be integrated in sizes that can be easily held in one hand.

3.7.2. The radio will be suitable for attaching a handheld microphone/speaker. Microphones/speakers will be provided at the rate of 20% of the total number of handheld radios.

3.7.3. Two lithium-ion or lithium-polymer batteries will be provided with each radio. Batteries will have a capacity of at least 1900 mAh. The batteries shall have been manufactured no more than one (1) year prior to the delivery date.

3.7.4. A battery charger will be provided with each radio. The battery charger will operate at 220 VAC. There will be a warning light on the charger. A vehicle charging kit will be provided for each device.

3.7.5. AF output power will be at least 0.5 Watt with 10% distortion.

3.7.6. The receiver sensitivity shall be at least 0.40 μ V for 12 dB SINAD in analog mode.

3.7.7. The radio will have at least IP54 protection rating.

3.7.8. The radio's internal speaker will have a minimum power rating of 1 W.

3.7.9. The radio will be supplied with a carrying case and strap for transporting and protecting the radio.

3.8. Mobile Radio Terminals

3.8.1. The radio will have an external speaker output jack. Each mobile radio will be supplied with one external speaker rated at least 5W and a mounting and connection cable.

3.8.2. The radio device will be powered from the 12 Volt vehicle battery; Appropriate cables and connectors will be provided. Battery connection cables will be in different colors to prevent reverse connection and will be protective against excessive voltage increases and will be at least 3 meters long.

3.8.3. SCA 20 model or higher 24V/12V converters will be given as 10% of the total number of mobile radios.

3.8.4. Each radio will be supplied with a push-to-talk handheld microphone complete with spiral cord and connector. If the radios have Bluetooth features in their catalogue, 10% of the total number of mobile radios be given Bluetooth-enabled push-to-talk handheld microphones.

3.8.5. One ASP 452 or equivalent mobile antenna (including all accessories) will be provided with each radio. The antenna cable will be at least 5 meters long, RG58/U UL1354 50 Ohm, and the connector will be provided. If an equivalent antenna is offered, the Purchaser's approval will be obtained before the antennas are delivered.

3.8.6. An antenna bracket and necessary mounting materials will be provided for each mobile antenna.

3.8.7. The mobile radio terminal will have a protection factor of at least IP54.

3.9. Fixed Radio Terminals

3.9.1. The fixed radio terminal will be delivered in a metal box with its power supply.

3.9.2. The power supply input voltage is 220 VAC \pm 20%, 50 Hz; the output power will be sufficient. AC-DC power cables of sufficient length will be provided with the device.

3.9.3. The power supply will have a protection circuit against overloading and short circuits and will have switch mode feature. The power supply will also be able to charge the 12 VDC 60 Ah radio battery in the Purchaser and the radio will automatically be powered from the battery in case of power outages.

3.9.4. The battery-powered radio will have a device that prevents reverse connection and will also have electronic circuits that prevent damage to the device in case of reverse connection.

3.9.5. Each radio will be supplied with a 30-meter length of RG-214/U coaxial cable. The cable will have an attenuation of less than 6.5 dB over 100 meters at 100 MHz and will meet MIL-C-17 standards (95% Cov.Rate). Cables will be delivered to the Purchaser in spools of no more than 100 or 200 meters without being cut.

3.9.6. 1 (One) handheld or table microphone will be given with each radio. If the radios have Bluetooth features in their catalogue, a Bluetooth-enabled push-to-talk handheld microphone will be given as 10% of the total number of fixed radios.

3.9.7. RF surge arresters at the appropriate frequency, which provide protection against lightning, will be installed on fixed radios.

3.9.8. One fixed antenna will be provided with each radio. Fixed antenna will meet PD-1142 specifications or equivalent. If an equivalent antenna is offered, the approval of the Purchaser will be obtained before the antennas are delivered.

3.9.9. If necessary, the supplier will provide suitable converter connectors between the radios used and the antenna.

3.9.10. The radio will have a protection factor of at least IP54.

3.9.11. At least 45m 10 mm² grounding cable and 6 grounding lugs will be provided for the grounding of each radio.

3.10. Technical Specifications of the Relay

3.10.1. Relay radios will be manufactured for continuous operation and be able to operate in both digital and analog modes.

3.10.2. The dimensions of the relay radio will be suitable for a 19" rack system.

3.10.3. One power supply will be provided with each relay. The power supply will be of sufficient capacity. AC-DC supply cables of sufficient length will be supplied with the relay. The power supply will have a protection circuit against overloading and short circuits and have switch mode feature. The power supply will also be able to charge the 12 VDC 60 Ah relay battery in the Purchaser. In case of power outages, the relay will automatically be powered from the battery.

3.10.4. Each radio will be supplied with a 50-meter length of RG-214/U coaxial cable. The cable shall have an attenuation of less than 6.5 dB over 100 meters at 100 MHz and shall meet MIL-C-17 standards (95% Cov.Rate).

3.10.5. The supplier will provide the necessary connectors for the relay and assemble it.

3.10.6. In order to provide protection against lightning, one each RF surge arrester will be used at a frequency appropriate to the RX-TX terminals of the relay.

3.10.7. One fixed antenna will be provided with each relay. Fixed antennas will meet PD 1142 specifications or equivalent. If an equivalent antenna is offered, the approval of the Purchaser will be obtained before the antennas are installed in their place.

3.10.8. For each relay antenna; The antenna pole to be provided by the Supplier will be installed on Offset or antenna apparatus.

3.10.9. For each relay; The relay will be grounded using at least 45m, 10 mm² grounding cable and 6 grounding lugs to be provided by the Supplier.

3.10.10. If system synchronization in relays will be provided via GPS, an external GPS antenna for each relay will be installed with the necessary apparatus and mounting material.

3.10.11. There will be indicators on the relay showing sending (TX) and receiving (RX) status.

3.10.12. The relay will have the feature of displaying the channel number, possible alarm condition and instantaneous noise level.

3.11. Technical Specifications of Control Center Software

3.11.1. Control center software will be provided by the Supplier and will include the features specified below. The specified features can be achieved using one or more software programs.

3.11.1.1. Configuring various types of equipment that make up the infrastructure,

3.11.1.2. Network Audit (controlling the equipment that forms the infrastructure over the network)

3.11.1.3. Network Management: Demonstration of network architecture

- 3.11.1.4.** Alarm Management (alarm processing, alarm status histories, live alarm display)
- 3.11.1.5.** Service Configuration (time-pressing, history and event records, mobile recording)
- 3.11.1.6.** Voice recording: All group and individual calls will be recorded and stored by the Control Center Software. The recording list will be automatically stored according to the ID numbers given to the radios in digital mode. Authorities and responsibilities can be determined to ensure that stored voice recordings are protected and can only be opened by authorized personnel.

3.11.2. Network Maintenance and Management. (Control and updating of infrastructure equipment over the network)

3.11.3. It will ensure that GPS data is sent automatically and periodically and all radios are managed. It will enable the geographical positioning of the selected radio in real time and/or the preferred time range and be displayed on the current or internet map. If necessary, the past route of the selected radio can be displayed and followed while navigating. The current software version of the radio, device information and the connection levels with the relay recorded in digital mode can also be viewed via the software. The coordinates of the radio will be accessible through this software.

3.11.4. The software version currently installed on the radio, device information, and connection levels with the relay registered in digital mode can also be viewed via the software.

3.11.5. All relays will be monitored remotely. When necessary, remote intervention and updates can be made to the relays. The required software can be installed on any authorized computer other than the server. GPS status of the relay, software version, noise level, output power, receiver and transmitter frequencies, IP address, etc. can be accessed via the software. information can be viewed.

3.11.6. Through the software, information such as the status of the call, from which user it was initiated, duration, etc. will be displayed instantaneously and retrospectively according to the ID numbers given to the radios in digital mode.

3.11.7. There will be an SNMP system to notify authorized personnel of instant alarms occurring in relays by e-mail.

3.11.8. There will be a relay analysis system that displays the noise levels of the relays, the number of radios connected to the relays and other alarm situations in graphs, instantly and retrospectively.

3.12. Notebook (9 units)

3.12.1. The processor will be at least i7 (3 GHz processor speed and 12MB cache).

3.12.2. The computer will have at least 16 GB 2600 MHz DDR4 RAM memory.

3.12.3. The hard disk will be at least 1 TB solid state drive.

3.12.4. There will be at least 2 USB 3.0 ports, one RJ45 port and one HDMI input on the computer.

3.12.5. The keyboard will have the Turkish Q keyboard feature and there will be Turkish characters on the keyboard.

3.12.6. The screen will be at least 15.6" LED screen with 1920x1080 FHD resolution that can provide images in outdoor environments.

3.12.7. The computer will have an integrated webcam, microphone and speaker.

3.12.8. Graphics Card must have at least 4 GB external memory.

3.12.9. The computer will be supplied with the Windows 11 Professional 64Bit system,.

3.12.10. Each computer must have its operating system pre-installed.

3.12.11. A wireless mouse will be delivered with the computer.

3.12.12. User manuals, help manuals and CDs will be delivered.

3.12.13. An extra rechargeable battery will be provided with each computer.

3.12.14. AC power cord, battery charger and carrying bag will be provided with each computer.

3.13. Server (9 units)

The Supplier will provide the number of physical servers specified in Section 2.1 with the following features in its bid:

3.13.1. Hardware Features

Configured with at least two (2) CPU sockets.
Chassis: 8 × 3.5" LFF drive bays; additional at least 5 empty LFF slots.
Integrated at least 4 × 1 GbE Ethernet ports.

3.13.2. CPU support:

Processor with at least 12 physical cores (24 threads) and a clock speed range of 2.1–4.0 GHz
Processor L2 cache at least 18 MB, L3 cache at least 35.75 MB.

A second processor of the same model can be installed if needed (motherboard has dual sockets).

3.13.3. Memory:

Total 128 GB (4 × 32 GB) DDR4-3200 MHz ECC.
There will be at least 4 additional empty DIMM slots.

3.13.4. For operating systems and critical applications:

2 × 1 TB NVMe SSD, RAID 1, high I/O performance.

3.13.5. For data storage:

3 × 2 TB SATA Enterprise SSD, RAID 5 configuration.
RAID controller: PERC H755 (NVMe & SATA, Battery Backup).

3.13.6. Networking:

Additional Intel X550-T2 2 × 10 GbE PCIe network card.

3.13.7. Expansion and redundancy:

At least 5 empty disk bays inside the chassis, multiple PCIe slots.
Dual at least 800W hot-swap power supply (PSR) redundant operation.

3.13.8. Optical drive:

Built-in DVD-RW read/write drive.

3.13.9. Operating system license:

Windows Server 2022 Standard, includes at least a 16-core CAL license.

3.13.10. Monitor, keyboard, mouse:

2 x 24" FHD IPS monitors (stand and HDMI cable included).
1 set of wireless keyboard and mouse

3.13.11. Manageable network switch:

At least 8 Gigabit ports, VLAN & L2 manageable.

3.13.12. Physical backup and maintenance:

Server rack mounting kit and cable management accessories.
All operating system, firmware, and RAID controller drivers will be pre-installed upon delivery.

4. DUPLEXER

4.1. The duplexer shall be suitable for operation in the 34-36 MHz frequency band and the 500 KHz receiver/transmitter channel frequency separation.

4.2. The duplexer shall be adjustable to the desired frequencies in the 34-36 MHz band, without the need for parts replacement, in accordance with the frequencies of the relay in which it will be used.

4.3. Each cavity shall consist of a total of 4 cavities, each independent of the other, with at least 190 mm diameter, including two High-Pass and two Low-Pass cavities.

4.4. The duplexer shall have bandpass and band stop features.

4.5. The signal attenuation rate of the bandpass part shall be at most -2 dB, and the signal suppression rate of the band stop part will be at most -80 dB

4.6. The outputs of the duplexer shall be compatible with the relay. RG-142 cables meeting M17/60-RG142 standards or RG-214/U cables meeting MIL-DTL-17 standards shall be provided for connecting cavities on duplexers.

4.7. One surge arrester for each duplexer shall be installed by the Supplier.

4.8. The duplexers shall be installed/delivered to the locations specified by the Purchaser

5. MICROWAVE LINKCOMMUNICATION SYSTEM (R/L)

5.1. The data transmission systems that will be installed over the wireless network will be based on IP (Internet Protocol) and the wireless systems that will be installed will comply with the rules and legislation of the Information Technology and Communications Authority (BTK) of Türkiye.

5.2. The point to point wireless communication system (Microwave Links) will operate on suitable Tx and Rx frequencies allocated to the Purchaser in the 10.5 GHz band for long-distance links, based on links planned with a professional microwave link planning program according to 99.95% availability principles. It will support the 15/18/23/38 GHz frequencies to be allocated by BTK for short-distance and high-capacity links. The frequency bands to be allocated by BTK (Information and Communication Technologies Authority) will be announced by the Purchaser prior to the tender date.

5.3. The radio link system will support adaptive modulation between QPSK and 1024 QAM modulations.

5.4. The microwave link wireless communication system to be established will have a minimum capacity of 100 Mbps in all directions and will be configured in a 1+0 configuration. No additional license shall be required for this purpose, and it shall be licensed indefinitely.

5.5. The antennas shall be radome-covered (designed to prevent damage from birds).

5.6. The metal materials on which the antenna will be mounted will be stainless steel, dip galvanized and weather resistant and shall be provided by the Supplier. If an antenna pole and/or antenna offset is required, all of these will be of sufficient length and quantity and shall be provided by the Supplier.

5.7. The necessary protocol and network configuration support shall be provided by the Supplier to prevent "loop" traffic between radio link directions and Ethernet ports and to maintain network connectivity.

5.8. The Ethernet ports must support the VLAN function (IEEE802.1Q), and it must be possible to configure VLANs based on ports and tags.

5.9. Each indoor unit must have at least 4 Fast Ethernet ports, these ports must be able to operate in a group and independently of each other, and the ports must be programmable as desired.

5.10. Each indoor unit must have at least 4 electrical and 2 optical 1 Gbps LAN ports in working order. The optical ports can be used by inserting a 1Gb electrical SFP and the licenses will be perpetual.

5.11. Each indoor unit must be able to configure XPIC on the backplane and must not require external cabling between modems. Necessary licenses will be issued.

5.12. Each IDU shall be equipped with two power supplies of sufficient power, low noise and minimal ripple. At least 2 ferrite cores will be used for each power supply.

5.13. Each ODU shall be grounded using a 10 mm² ground cable to the equipotential busbar.

5.14. The software and equipment necessary to operate the radio links shall be provided.

5.15. There shall be LEDs on the radio link indicating the status of Tx, Rx, Power.

5.16. Standard RF and/or Ethernet cables shall be used in the installation of radio links.

5.17. Lightning protection units (surge arrestors) will be provided for the outdoor units and indoor units of radio links that are actively used.

5.18. The devices to be installed must support the feature of carrying traffic and management data together (inband management or management over VLAN).

5.19. Network management system will be provided by the Supplier for the centralized management of radio links (configuration, software updates, etc.) through a single interface. Licensing will cover at least 30% more points than the number of points provided within this contract.

5.20 Link Indoor (IDU) and Outdoor (ODU) Unit Features:

5.20.1 IDU:

5.20.1.1 Ethernet ports shall be (10,100,1000) Mbps

5.20.1.2 Shall run as Half and Full Duplex.

5.20.1.3 Shall have MSTP feature.

5.20.1.4 Shall support 1+1 SD/FD/HSB link configurations, and the delivered product will be 1+0 configuration.

5.20.1.5 Modulations between QPSK to 1024QAM modulation shall be provided.

5.20.1.6 BW: (7,14,28,56) MHz will be supported.

5.20.1.7 Shall have IF input and output in 4 directions.

5.20.2 IF Modem Card:

It shall be removable and installable, capable of transmitting and receiving in two directions, and shall support adaptive modulation between QPSK to 1024QAM modulation types.

5.20.3. ODU:

5.20.3.1 It will operate on suitable Tx and Rx frequencies in the 10.5 GHz band allocated to the Purchaser for long-distance links. It will support the 15/18/23/38 GHz frequencies to be allocated by BTK for short-distance links requiring high capacity.

5.21 ANTENNA POLES AND OFFSETS

Pole

5.21.1 Pole mountings on the building should be made in places corresponding to the columns or beams. Installation will be done using polyurethane mastic to seal the building.

5.21.2 Anchoring rods of appropriate length should be inserted into the column or beam, and clip-on dowels should be used.

5.21.3 All 10 or 12-meter pole systems installed will have a working platform. The pole system will have an internal ladder.

5.21.4 Poles shall consist of a maximum of 4 flanged pipe sections.

5.21.5.A ground geotechnical survey shall be conducted for the pole, and excavation will be carried out as necessary in accordance with the project.

5.21.6 The concrete used in the foundations of the poles and supports shall meet the local and international appropriate standards.

5.21.7 After the concrete part of the excavated pole foundation is completed, if the soil characteristics are not suitable for this work, filling will be done using a suitable material mixture (gravel, etc.).

5.21.8 Each 10 or 12-meter pole system shall be equipped with a catch rod, which shall be connected to the grounding system using a conductor mounted with $\Phi 8$ clamps. The base of the catch rod shall be constructed using a transport-mounting apparatus so that it is at least 5 meters above the highest point of the pole. The end tip of catch rod shall be the highest point on the pole.

5.21.9 Poles and offset parts will be manufactured in accordance with TS EN ISO 1461 standards, using hot-dip galvanizing.

5.21.10 Poles shall be designed as anchored braced poles.

5.21.11 It shall be designed in accordance with the TIA/EIA-222-G standard.

5.21.12 Design Wind Speed: 160 km/h -- At the midpoint of the tower's height, the Antenna Surface Area shall be 5 m².

5.21.13 The displacement factor at operational wind speed will be %0.5.

5.21.14 Material Quality: S235JR and S355JR (EN10025) will be used.

5.21.15 Bolt Quality: 8.8 (DIN7990).

5.21.16 The top 4 m section of the pole shall be used for antenna and camera installations. Therefore, the support connection points will be at least 4 m below the top of the pole.

5.21.17 An interface shall be provided at intervals of no more than 80 cm along the last 2 m of the pole, where cable clamps shall be secured.

Offset

5.21.18 For R/L, the pipe of K1 offsets will have 1.5m, 2.5" and 4mm wall thickness.

5.21.19 The pipe of the K1 round type offsets for the relay will be produced with a wall thickness of 2 m, 2", 4 mm and suitable for the pole.

5.21.20 7 cm screws will be used in offsets.

6. CABINET (78 Units)

6.1. The cabinet must have a cover that can be accessed from the side, front and rear. The cabinets will be used indoors. The covers are lockable and the keys will be labeled and delivered to the relevant parties.

6.2. The front and rear doors of the cabinet should be made of perforated grilles and allow air circulation. Perforated grilles must have a structure that prevents the entry of dust and similar foreign substances into the cabinet.

- 6.3. The cabinets will allow the installation of 19" wide devices.
- 6.4. The cabinet will be wheeled or fixed and will be mounted in a location deemed appropriate by the Purchaser.
- 6.5. The cabinet will be metal and antistatic painted.
- 6.6. There will be a surge arrester in each cabinet.
- 6.7. All devices in the system will be protected by overvoltage protection products. The protection modules to be used must be such that they do not disrupt the operation of the system. Protection products must have the following features:
 - 6.7.1. The protection product is not against permanent over voltages; It will have a structure that will provide protection against instantaneous voltage surges.
 - 6.7.2. The protection product will be connected in front of the devices to be protected.
 - 6.7.3. The response time of the protection product must be appropriate for each device used in the system.
 - 6.7.4. The protection product will be tested according to IEC 61643-1 standard.
 - 6.7.5. The protection product will be in IP 20 protection class according to IEC 60 529/EN 60 529.
- 6.8. Cabinet, link main device, NVR, surge arrester, power supply etc. It will be large enough to fit the devices.
- 6.9. The cabinets must have a ventilation system consisting of 4 fans and a temperature-adjustable thermal control circuit.
- 6.10. There will be a mounting rail inside the cabinet where panel type equipment can be mounted.
- 6.11. There will be 2 sliding and 2 fixed (adjustable) shelves in the cabinet.
- 6.12. There will be at least 6 multiple sockets with fuse protection at the back of the cabinet.

7. FIXED SOLAR ENERGY SYSTEM

7.1. GENERAL PROVISIONS

- 7.1.1. The solar panels, charge control unit, inverter and batteries to be offered will comply with at least one of the international standards IEC, VDE, DIN and the standard followed will be specified in the offer.
- 7.1.2. All products offered will have CE certification.
- 7.1.3. The system will operate at a voltage of 220V, 230V, or 240VAC, at a frequency of 50 Hz, with a minimum rated output current of 6.5A.
- 7.1.4. The system will operate up to 90% relative humidity.
- 7.1.5. The system will operate in locations where it is installed at altitudes between sea level and 2250 m.
- 7.1.6. Each panel group will be protected against lightning with a surge arrester before connection to the control unit. The surge arresters to be used will be suitable for solar systems. There will be no breaks, cracks, paint defects, swelling or deformation in the system.
- 7.1.7. Each system will be supplied with a 25-meter extension cable of at least 3x2.5 mm, complying with the IP 44 standard, which is resistant to water and moisture and can work in outdoor environments.
- 7.1.8. The photovoltaic panels used in the energy production system will be in sufficient quantity to provide a minimum power of 3500W (STC: 25°C temperature, 1.5 Atmospheric Pressure, and 1000W/m² irradiance value).
- 7.1.9. The average sunbathing time will be assumed to be 6 hours.
- 7.1.10. A fixed solar energy system will be used to meet the electrical energy required for the digital radio communication system.
- 7.1.11. In accordance with the requirements of this specification, the electricity demand will be met by solar panels with a total power of at least 3500W (STC), and the output voltage level of the system will be suitable for the operation of the equipment to be used at the facility.
- 7.1.12. The charge control unit and converter (inverter) will be offered as separate devices. They will not be integrated and will be hot-swappable.
- 7.1.13. Installation of solar panel, charge control unit, inverter, module connection elements (appropriate cross-section) with cables and connections shall be done by the Supplier and shall be included in the bid price.
- 7.1.14. Each system will be assembled and delivered in an operational state by the Supplier.

7.1.15. All materials, accessories, mounting hardware, and system components (solar panel, inverter, controller, distribution panel, etc.) will be standard models manufactured as the latest and most recent versions, and the period between the delivery of the batteries and production will not exceed 12 months.

7.1.16. The units to be used for each system will be exact and identical to each other.

7.1.17. Indoor cabinets shall be equipped with cooling fans rated at a minimum of 1,000 watts

7.2. SOLAR PANEL

7.2.1. The open-circuit voltage of the solar panel will be at least 50V. The panel efficiency will be at least 22%.

7.2.2. Panels will be practicable for serial and parallel connection as needed. Serial and parallel interconnection cables for the panels will be provided free of charge.

7.2.3. The working life of the panels will be minimum 20 years. Solar panels will have at least 2 years factory warranty, 10 years 90%, 15 years 80% productive warranty.

7.2.4. Each solar panel in the energy system production will have a minimum power of 550W. (STC: Irradiance 1000W/m², Panel Temperature 25°C, AM=1.5)

7.2.5. The panels used in the energy production system will have 3 (three) "By-Pass" diodes that will protect the solar panel in parallel connections.

7.2.6. Solar panels used in the energy production system will comply with IEC 61215 and IEC 61730 standards.

7.2.7. The frame of the solar panels used in the energy production system will be aluminum. The frame, connection point and elements will be resistant to corrosion and stainless.

7.2.8. Front surface will be made of high-transmittance tempered glass. It will be resistant to external stresses. It will withstand wind loads of 2400 Pa and snow loads of 5400 Pa.

7.2.9. Cables from solar panels used in the energy production system will be protected with solar array protection fuses and surge arresters. No cables will be left exposed at connection points; rings and lugs will be used in all cabling. Connections between panels will be provided via MC4 sockets. The necessary safety equipment must be installed between all these connections. The values of these safety elements are specified in the relevant sections. International color codes will be followed for cables. (In AC current: yellow-green color is ground, blue color is neutral, other colors are phase; in DC current: red color is positive, black color is negative.)

7.2.10. Reverse side will allow the panel to be mounted on stands and it will be resistant to harsh climatic conditions (wind, snow, rain, etc.). It will have practical montage and dismantling, and the panels will be made of stainless bolts-nuts and materials that can be placed and removed.

7.2.11. Module connection box will be made of high impact resistant, high electrical energy resistant, rain proof and pressure resistant material.

7.2.12. Panels and fasteners will be constructed to withstand wind speeds up to 120 km/h.

7.2.13. Panels will run properly at -40 C and +80 C ambient temperatures, at an altitude of 0-2250 m, up to 90% relative humidity.

7.3. CHARGE CONTROL UNIT

7.3.1. The charge control unit will transfer the DC power generated by the solar panel array to the common DC bus and will have the capacity to supply both the load and the batteries simultaneously.

7.3.2. The charge control unit will be suitable for battery charging at 12-24 and 48 Volt (DC) standards. The output voltage will be adjustable within the range of 48-54 VDC. The MPPT operating range will be within the range of 100-380VDC. The start-up voltage will be 150VDC.

7.3.3. The charge controller will be capable of performing power conversion appropriate for the solar panel power. The operating MPPT voltage level will be suitable for the panel group.

7.3.4. The charge control unit will be capable of carrying a minimum of 60 Ampere DC current along with the battery charging current and system load.

7.3.5. The charge control unit will be capable of protecting the battery group from overcharging. This protection will disconnect the solar panels from the circuit.

7.3.6. The charge control unit will automatically activate while protecting the battery pack from overcharging or discharging and will not require a restart. If the system voltage returns to the specified values, it will continue to operate without the need for any intervention.

7.3.7. The charge control unit will have the features of automatic voltage detection, charging with MPPT control technique, automatically disabling the load according to the charge status, and automatically reactivating the load according to the charge status.

7.3.8. If the solar energy produced is insufficient, it will allow the systems to be fed from the battery group, and if the battery voltage drops to a certain level, it will disconnect the battery group from the load to protect it from deep discharge.

7.3.9. The charge control unit will be reactivated as a result of the protection it provides during overcharging or discharging of battery groups, and will not require special applications such as restart or reset. If the system voltage returns to the specified values, it will continue to operate without the need for any intervention.

7.3.10. In the charge control unit; There will be an energy system panel showing the battery capacity, the charging current coming from the panels, and the current drawn by the load. These values will be displayed on the built-in LCD panel.

7.3.11. All elements used in the charge control unit will be easily accessible.

7.3.12. The charge control unit's electrical and electromechanical materials will operate smoothly at an ambient temperature of -10°C to +50°C, at an altitude of 0-2250 m, and at a relative humidity of 90%.

7.3.13. No additional device will be required to adjust the charge control unit (battery type, buffer charge voltage, battery capacity, overcharge, deep discharge values).

7.3.14. There will be reverse polarity protection, lightning protection, noise protection, reverse leakage protection, short circuit protection, overload protection, sudden voltage change protection.

7.3.15. The control unit will be equipped with an external temperature sensor. It will feature a temperature-compensated battery charging technique based on changing temperatures. Battery temperature will be monitored via the LCD panel and interface software.

7.3.16. The charging unit will be rack-mounted inside the container.

7.3.17. The control unit will comply with the electrical safety standards EN 60950-1 and EN 62368-1, and the electromagnetic compatibility standards EN 61000-6-1, EN 61000-6-2, EN 61000-6-3, and EN 61000-6-4.

7.3.18. The charge control unit, the inverter unit connected to the system via the control unit, and the batteries can be monitored via IP-based interface software.

7.3.19. The charging control unit will support SNMP V1, V2, V3 communication protocols and Modbus TCP communication protocols.

7.3.20. The MIB tree for communication protocols and the Modbus Map will be submitted to management during the construction phase.

7.3.21. The interface will display the total panel voltage, charge controller output voltage, total load (power or current), battery temperature, battery charge/discharge current, inverter output power, internal unit temperatures, alarm status, alarm and event log records, and daily and weekly energy data log records. There will be administrator and user level login options.

7.4. BATTERY

7.4.1. The batteries will consist of 48V blocks with a built-in battery management system, featuring 3.2V cells made of Lithium Iron Phosphate (LiFePO₄) technology, which are maintenance-free and resistant to deep discharge.

7.4.2. Each battery must have a capacity of at least 100Ah at 25°C. The total nominal capacity of the batteries to be used in the battery pack will be at least 400Ah (19,200Wh) at 20°C, at the C10 (10-hour rate) value.

7.4.3. Batteries will have at least 3000 charge-discharge cycles, each discharging to 80% of their capacity.

7.4.4. Will not release gas during charging and use.

7.4.5. Battery terminals will be resistant to corrosion and suitable for high current transmission. Battery connection equipment will be isolated.

7.4.6. Batteries must be able to operate at ambient temperatures between 0°C and +50°C.

7.4.7. Battery terminals will contain positive (+) and negative (-) free antimony

7.4.8. Batteries must be charged using the appropriate lithium-ion charging technique.

7.4.9. Batteries will run properly up to 90% relative humidity when installed at an altitude of 0 - 2250 m

7.4.10. Battery surfaces will be resistant to external impacts and factors.

7.4.11. Each unit will have a battery appropriate to its capacity.

7.4.12. The period between the delivery of the batteries and production will be less than 12 months.

7.4.13. Batteries will be of a type that does not leak the substance they contain.

7.4.14. Batteries will be manufactured in accordance with ISO 9001 and ISO 14001 standards. Batteries will comply with the UN38.3 standard.

7.4.15. Batteries will be 19" rack type and will be mounted in an internal rack cabinet inside the container.

7.4.16. The cable used for the connection between the charge control device and the battery group will not be less than 25 mm² in cross-section.

7.4.17. Batteries will have indicator lights showing the charge status. Dry contact outputs will be provided for fault indication. An internal Ethernet connection will be provided.

7.4.18. The batteries' internal Battery Management System will have a cell-to-cell balancing feature that ensures equal charging of the battery cells. The battery management system will have protection against overheating, overcharging, over-discharging, and short circuits.

7.4.19. The 48V battery blocks will be capable of being connected in parallel in sets of 6. No additional unit will be required for parallel connection.

7.5. INVERTER

7.5.1. A device that converts the DC voltage received from the battery and charging control unit into 220V, 230V, or 240V 50Hz AC voltage.

7.5.2. The inverter unit must provide a continuous power output of at least 1500VA at 24C. The power modules will be socketed type with N+1 redundancy. One unit will meet the entire power requirement, while the other will be a backup.

7.5.3. There will be short circuit protection at input and output.

7.5.4. There will be overload and overheat protection

7.5.5. There will be advanced front panel functions (LED or LCD display) and will give an audible warning in case of malfunction.

7.5.6. The converter unit will perform the conversion process with high accuracy under microprocessor control.

7.5.7. Device efficiency will be at least 94%.

7.5.8. Device will have true sinusoidal output waveform.

7.5.9. There will be reverse connection protection at the input.

7.5.10. The device will be produced in accordance with EN 61000 standards.

7.5.11. The converter unit will run properly at operating temperatures between -20C and +50C.

7.6. DISTRIBUTION PANEL

7.6.1. Solar Panel Distribution Panel:

7.6.1.1. The inverter, charge controller, and solar panel connection distribution panels may be separate or in the same panel cabinets and will be placed inside the container.

7.6.1.2. Distribution panels will contain suitable rail systems for fuses and connection contacts.

7.6.1.3. Connection points suitable for mounting the inverter and charge regulator and for easy removal and installation will be provided.

7.6.2. AC Output Panel:

7.6.2.1. The AC output panel will have automatic fuses and terminal connections according to the number of lines to prevent minimum voltage loss. Labels will be pasted on the connection points. Labels will be durable and will not come off.

7.6.2.2. There will be digital voltmeter and ammeter LCD indicators on the AC output panel.

7.7. FIXED SOLAR PANEL STAND

7.7.1. It is the mechanical part on which solar panels will be mounted.

7.7.2. The fixed solar panel stand will be anchored to the site concrete using chemical anchors, facing south, and the necessary gaps will be left between the panels to minimize wind impact.

7.7.3. The panel stand will have a fixed inclination angle of 35°. The height of the solar panel stand will be at a height that will not be affected by the shadow of the fence surrounding the site.

7.7.4. All metal parts, welds, drill holes, etc. will be galvanized to prevent rusting after completion of work.

7.7.5. Tables will be made of corrosion-resistant material suitable for environmental conditions. The profiles used will be hot-dip galvanized. Fasteners will be made of stainless steel.

7.7.6. The panel stand will be made of material with a suitable cross-section and dimensions to withstand the wind load specified for solar panels and any snow load that may occur. The ground connections will also be capable of carrying these loads.

7.7.7. The panel stand will be manufactured from material capable of withstanding up to 90% relative humidity without issues when installed at ambient temperatures of -40°C to +80°C and altitudes of 0 to 2250 m.

8. ELECTRICAL GROUNDING

8.1. Grounding electrodes (rod or plate), grounding conductor (solid copper) and grounding bar will be used in the installation of the grounding system. Grounding electrodes for the pile will be $\Phi 20$ mm in diameter and at least 1.5 m long, and will have the features specified in the Ministry of Environment and Urbanization exposure number 35.750.4001.

8.2. All chassis parts within the container will be connected separately to the internal grounding busbar. An earth busbar will be mounted inside the container and connection will be made with the building earth busbar.

8.3. The panel fence enclosure system must be grounded from at least 4 points.

8.4. The grounding resistance value shall be maximum 5 ohms. The required number of grounding elements will be installed to ensure the value in question. When more than one grounding element is used, the distance between the elements will be at least the length of that element.

8.5. Grounding elements will be at least 150 cm away from the system they ground. All grounding elements will be 150 cm away from the building or antenna mast.

8.6. The grounding elements will be filled with resistance-reducing material (gem dust) and vegetable soil.

8.7. All grounding interconnections will be made with 50mm² NYA cable. The ring installation between the rods will be made with 2x50mm² solid copper wire. No splices will be made in the cables used in grounding interconnections.

8.8. All connections will be made by thermo welding method and the original crucible suitable for the welding type will be used.

8.9. Ground and energy cables will be processed separately and shall not be placed closer than 50 cm to each other inside and outside the building.

8.10. Before the grounding installation is closed, the measurement report will be prepared by the Supplier and submitted to the Purchaser.

8.11. A test terminal will be left for each grounded unit in order to measure the grounding.

8.12. Grounding elements and all grounding installations will comply with the Grounding Facility Regulation and the General Technical Specification of the Ministry of Environment and Urbanization.

8.13. Grounding Ring

8.13.1. If the grounding resistance cannot be achieved, new grounding elements can be installed in suitable areas, continuing from the grounding elements forming the main ring. In this case, the grounding conductor must be transported to a depth of at least 90 cm from the soil surface and the grounding elements must be installed in the manner specified in this specification.

8.13.2. 2x50mm² solid (filled) copper conductor will be used as ring conductor.

8.13.3. The ring grounding conductor will be at least 90 cm deep from the soil surface.

8.13.4. If any place other than the Digital Radio Communication System is used (Fire Watchtower, GSM Tower, etc.), the grounding of both systems will be combined with an equipotential bar.

8.13.5. Solar panel stands will be grounded at their feet. In double-row solar panel arrays, inter-array panel grounding will be provided. The ground connection of the surge arrester located within the array protection panel will be ensured.

8.14. Grounding of Mineral Franklin Rod

8.14.1. The metal capture tip to be installed on the antenna tower will have a diameter of $\Phi 20$ mm, a length of 800 mm and the features described in the Ministry of Environment and Urbanization No. 35.750.1100. The base of the mineral capture end will be made using a transport-mounting apparatus, at least 5 meters above the highest point of the tower. The capture tip will be higher than the other materials mounted on the tower.

8.14.2. 2x50mm² solid copper conductor will be used as the down conductor.

8.14.3. The down conductor will be attached to the antenna tower with steel clamps.

8.14.4. The down conductor will be nailed at the farthest point from the tower within the panel fence and will be connected to the grounding electrodes installed in a triangle shape. The electrode will be connected to the ring from the shortest point.

8.14.5. The grounding conductor will be protected with 2 meters of galvanized pipe upwards from the entrance to the ground. A test terminal will be installed for measurement.

9. CONTAINER

9.1. CHARACTERISTICS OF CONTAINER

9.1.1. The container will have dimensions of at least 2x2x3 m (Length x Width x Height). The Supplier will detail the container dimensions in the technical specification answers document (technical drawing).

9.1.2. All parts of the container will be manufactured suitable for assembly and disassembly. The container will have solid legs of at least 10 cm. The legs will be considered together with the container so as not to cause any static problems.

9.1.3. There will be hanging eyebolts at the necessary points to lift the fully equipped container.

9.1.4. The outer part of the walls, floor and ceiling will be manufactured from trapezoidal galvanized sheet metal with a thickness of at least 0.80 mm in accordance with TSE 822 class ID and will be painted with electrostatic polyester powder paint with an average paint thickness of 60 microns and baked. Color codes will be determined later by the Purchaser.

9.1.5. The inner surface of the walls and ceiling will be chipboard with a thickness of at least 12 mm in accordance with TS 901, and there will be 60 mm (polystyrene hard foam TS 7316 EN 10163, density 36 kg/m³) thermal insulation material between the interior and exterior walls of the building and on the ceiling. Profiles will be placed at appropriate intervals from the inside to prevent the chipboard from swelling.

9.1.6. Container floor, chassis detail of at least 0.80 mm trapezoidal section sheet, 20 mm insulation material Styrofoam (polystyrene hard foam TS 7316 EN 10163, density 36 kg/m³), on 18 mm betopan application, thickness 2.5 mm, 60x60 cm It will be laid with homogeneous antistatic PVC floor covering material with a conductivity resistance of 106K Ω . A profile designed to carry the device loads will be placed in accordance with the placement of the device (cabinet, panel, etc.) to be given. All materials to be used here will comply with the latest published TSE standards.

9.1.7. The external door will be specially profiled and locked, made of 1.5 mm thick electrostatic painted galvanized sheet metal, in accordance with TS 822. Barrel lock complying with TSE standards will be used. All locks will be made to be opened with a single key. The door leaf size will be minimum 100/210 cm and open outwards. There will be a rain dropper on the door.

9.1.8. There will be a container-mounted foldable grill for wiping feet in front of the outer door.

9.1.9. Bolts and nuts used in container assembly will be stainless galvanized. Bolts and nuts complying with ASTM.A153 and the latest TSE and EN ISO standards will be used.

9.1.10. The carrier system of the container is designed to carry a snow load of 80 kg/m². It will be designed by making static calculations on the basis of being in first degree seismic zone.

9.1.11. The container carcass and the parts completing the main structure will be manufactured from steel profiles. These profiles will be electrostatic powder painted. Closing profiles to be used inside and outside the container will be manufactured to provide the necessary sealing.

9.1.12. A rain slope (free flow) will be provided on the container roof or the necessary drainage system will be built to prevent rainwater from accumulating on the roof.

9.1.13. A thermostatic aspirator fan will be installed in the container and the necessary electrical cables will be installed. At each cable passage from inside to outside of the container, the necessary sealing will be provided with cable and pipe insulation solutions.

9.1.14. For lighting, 2 pieces of 10W LED fixtures will be mounted on the ceiling. Luminaire switches will be mounted on the wall next to the door.

9.1.15. An LED lighting with a switch and a capacity to illuminate at least 5 m² of area will be placed on the container entrance door. The outdoor lighting fixture will have IP45 protection level.

9.1.16. Cable entry shaft into container; Energy input and RF cable entries will be separate.

9.1.17. The devices inside the container will be connected to the protection grounding by combining them with an equipotential busbar.

9.1.18. There will be a grill type ventilation window, measuring 30x30 cm, that can be opened and closed from the inside, on two opposite walls. There will be a rain dropper on the window and sufficient insulation will be provided to prevent water entry from the edges. A filter will be used to prevent dust entry.

9.1.19. Inside the container, there will be a shelf system with adjustable shelf spacing consisting of at least (5) shelves in the form of a 19" rack fixed to the wall of the container from floor to ceiling, which can accommodate the devices to be used in the system. When mounting the shelf to the container, a sufficient working space will be left around the shelf system.

9.1.20. There will be 1 folding chair in the container.

9.1.21. The Purchaser has the right to change the way of using the container if it deems it necessary, provided that the size and features remain the same.

9.1.22. Container grounding will comply with the Grounding Facility Regulation.

9.1.23. The container will be installed in accordance with residential and electrical projects.

9.1.24. A collapsible type aluminum portable ladder of sufficient length will be provided to climb onto the container (the closed version must be able to fit inside the container).

9.1.25. Preparation and Assembly of Container Foundation

9.1.25.1. The container will be placed on its level on the concrete platform. The container will be mounted on the foundation concrete in a way that it can be removed from the legs. Connection parts will be stainless galvanized according to TSE 914 EN ISO 1461.

9.1.25.2. Container basement will be at least 30 cm; Foundation concrete dimensions will be at least 5x10 m and concrete thickness will be at least 12 cm. (The Purchaser may change the measurements when necessary, according to land conditions)

9.1.25.3. The container platform will be at least C25/30 class iron reinforced (mesh steel) concrete on all types of ground. Before the concrete platform is built, the upper part of the ground will be leveled horizontally and the concrete platform will be built on a solid foundation.

9.1.25.4. Containers will be mounted on the platform to withstand 130 km/h wind speed.

9.1.25.5. The container door will face east or west. The RF input channel will be above the diagonal corner of the container's entrance door. If necessary, the opinion of the Purchaser will be taken.

9.2. SHUTTER ASPIRATOR FAN

9.2.1. The flow rate of the fan will be at least 500 m³/h.

9.2.2. The fan body and propeller will be composite.

9.2.3. The fan will be thermostat controlled. The fan will automatically turn on when the temperature rises above the set value.

9.2.4. It will be mounted in such a way that there will be no water leakage from the point where the body will be mounted to the container.

10. LATTICE ANTENNA TOWER

10.1.1. The Supplier will submit the project of the lattice antenna tower to the Purchaser following the signing of the contract.

10.1.2. Lattice antenna towers will have 4 (four) legs. The tower height will be 24 meters from the ground.

10.1.3. The antenna tower, fasteners and all parts will be manufactured from S235 and/or S355 type steel specified in EN 10025-1 and ECISSE IC10 standards and will be galvanized by hot dip method in accordance with TSE 914 EN ISO 1461 standard.

10.1.4. Dimensions and tolerances of raw materials will be checked according to relevant DIN, EN and/or ISO standards, and materials that do not meet the standards will not be used. Test certificates will be issued for the steel used in production. Test certificates will include the mechanical and chemical properties of the material used.

10.1.5. TSE - TS ENV 1993-3-1(2007) standard will be complied with in antenna tower design and installation.

10.1.6. All bolts used in the tower will be designed and applied to exceed the nuts by a minimum of 3 threads. Each bolt connection point will have a minimum of one nut, one washer, and one spring washer. If the foundation is designed with anchors, the anchors will be designed to reach the base of the foundation.

10.1.7. It will be assumed that the antenna areas to be used in wind load calculations are concentrated at the top of the tower.

10.1.8. The lattice antenna tower will be resistant to ice load of at least 1.5 cm thick. The antenna tower will be designed to prevent snow and ice.

10.1.9. The operational wind speed of the lattice antenna towers will be 160 km/h in an area of 5 m². The antenna areas given above will be used in the wind load calculation. At operational wind speed, including loads and fields, bending and torsional displacements at peak will remain within logarithmic degree of displacement 1.0 (one degree) in all directions. Linear solution will not be accepted in displacement calculation. Antennas installed on the lattice antenna tower will not affect this displacement. Flexures in the antenna tower will not prevent the radio link antennas on it from working. Lattice antenna tower static calculations will be made according to the 1st degree earthquake zone.

10.1.10. The cutting process of the parts that will form the antenna tower will be done with scissors or saw, and manually controlled oxygen source will not be used. Burr etc. that will occur during cutting, will be cleared. All holes will be drilled before galvanizing. During the drilling process, holes to be opened in all steel parts that are 10 mm and thinner will be opened with a punch of full diameter unless otherwise requested. Holes to be opened in steels thicker than 10 mm will be pre-drilled with a drill or punch and reamed to the required diameter. All holes will be clean, tear-free and smooth. The finished diameter of reamed or drilled holes will not be more than 1.5 mm of the nominal bolt diameter. The tolerance for the spacing of all bolt holes will be no more than 0.8 mm.

10.1.11. There will be a total of 2 working and resting platforms in the antenna tower. Working platforms will have a central outer section protected against falling.

10.1.12. Platforms will have a grated or expanded sheet structure to prevent snow retention and slipping, and will be large enough to cover the inside of the tower.

10.1.13. An ice shield will be installed to protect the equipment mounted on the antenna tower.

10.1.14. A smart aircraft warning lamp will be connected to the antenna tower. The smart aircraft warning lamp will be produced with LED technology, low intensity, does not emit RF waves, has IP 65-66, CE, TSE standards, and will have a fault alarm dry contact output. The warning lamp will be redundant, and in case of failure of one group, it will be able to automatically switch to the other. The warning lamp will be mounted on the top of the lattice antenna tower, the power and control cable will be pulled to the panel and delivered in working condition.

10.1.15. Along the pole, there will be an internally protected climbing ladder and a cable duct parallel to this ladder. The cable duct will be within easy reach of a person on the ladder. There will be no protection at the transition parts of the climbing stairs to the platforms.

10.1.16. The spacing at the connection points on the climbing ladder will be the same size as the other leg spacing. No cables on the tower will be installed via a climbing ladder.

10.1.17. There will be vertical and/or horizontal lifelines in the antenna tower in accordance with occupational safety principles.

10.1.18. Foundation concrete, field concrete, excavation, backfill, etc. will belong to the Supplier. Expenses for Concrete Test Report will belong to the Supplier. If the on-site experiments and tests are not deemed sufficient, the Purchaser may have experiments and tests carried out in other institutions, at the Supplier's expense.

10.1.19. Lightning catch and cabling will be installed in the antenna tower in accordance with the "Lightning Protection Regulation".

10.1.20. Lattice Antenna Tower Installation

10.1.20.1. The supplier; The ground type of the area where the tower will be installed will be determined, a foundation project suitable for the ground will be made and the installation will be carried out.

10.1.20.2. Foundation projects will be created according to two separate calculation criteria for normal soil (1.5 kg/cm²) and rocky soil (greater than 3.0 kg/cm²). Soils smaller than (1.5 kg/cm²) will be considered as weak soils, and foundation calculations will be made for these soils according to the soil survey report. Responsibility for the ground will belong to the Supplier.

10.1.20.3. In order to protect the pole foundations on the slopes or to provide additional tensile strength, terracing, embankment, curtain covering or retaining walls will be built. In the construction of the retaining wall, foundation calculations and reinforcement calculations will be made according to the ground structure and slope condition, and concrete of at least C25 quality will be poured. The material to be used in riprap construction will be solid and durable rocks, each weighing approximately 45 kg and at least 12 cm in diameter or thickness, or broken concrete masses without reinforced concrete iron ends protruding from the inside out. These will be laid with close joints and will be firmly placed on the sloping soil surface.

10.1.20.4. Excavation will be carried out in accordance with the ground survey and project of the tower. Tower foot depths will be equal. Tower foundations will be installed in accordance with the ground. In sites with elevation differences, concrete stairs will be built at the entrances.

10.1.20.5. All concrete manufacturing to be used in tower foot foundations, in the field and for other works will be at least C25 class, and concrete reinforcement will be in accordance with TS 708. TS 500 and the latest specifications of the Ministry of Environment and Urbanization will be complied with in the design of tower foot foundations. 10 cm of lean concrete will be placed under the foundation concrete, and care will be taken to place the reinforcing bars with a 5 cm spacer. A vibrator will definitely be used during concrete pouring.

10.1.20.6. The dimensions between the tower legs, the assembly of which has been completed in appropriate length, will be in accordance with the tower project, with no difference in elevation between the two adjacent legs and the diagonal legs. All tower legs will be in exact balance with each other. Field concrete will be made between the tower legs.

10.1.20.7. After the concrete parts of the excavated tower foundations are completed, if the soil conditions to be filled are not suitable for this job, material suitable for these conditions (gravel, etc.) will be found and the filling will be made using the appropriate mixture. There will be no large rocks, trees, mud, various plants or tree residues in the soil to be filled. The filling of the tower feet will be wetted with water and allowed to collapse, then the feet will be filled again. This process will continue until the filler is thoroughly compacted.

10.1.20.8. The Supplier will have the designs of the antenna towers (including the basic designs) approved by an authorized academic institution (university approval) deemed appropriate by the Authority, upon the Authority's request. The static analysis program used to calculate the tower (Tower, Pls Tower, Risa Tower, etc.) will be provided to the Purchaser along with its license, and the program inputs and outputs of the calculations will be presented in computer format. Calculation reports and projects will be provided to the Purchaser on CD in the form of AutoCAD files containing detailed drawings.

11. PHYSICAL SECURITY EQUIPMENT

11.1. In line with the layout plan, the area will be surrounded by a panel fence (in accordance with the technical drawing below). The perimeter length for the system will be at least 30 m [2x (10+5) m]. Measurements may be changed by the Purchaser according to land conditions and needs and will be carried out by the Supplier without requesting an additional fee.

11.2. Physical security materials will consist of panel fence, mounting poles, razor wire.

11.3. Panel fence will consist of panels with 5cm x 15cm mesh opening, at least 200 cm high and 250 cm long. The steel wire to be used in the panel fence will be hot dip galvanized with a thickness of at least 5 mm. The panels will be coated with baked polyester-based electrostatic powder paint or PVC-based thermoplastic powder paint.

11.4. The poles to be used for the panel fence will be steel, 60mmx60mm x 2.5mm dimensions, hot-dip galvanized inside and outside, box profile.

11.5. The panels will be attached to the poles with at least 3 clips.

11.6. The poles will be mounted on the concrete beam with flanges and will be mounted using steel dowels from at least four points.

11.7. The reinforced concrete foundation for the panel fence posts will be constructed of reinforced concrete (minimum C25 grade) in a continuous strip measuring 20x40 cm along the entire length of the fence.

11.8. Internal and external water drainage of the panel fence mesh will be provided.

11.9. 4 electrostatic painted warning signs will be placed on galvanized sheet metal with dimensions of 30x40 cm.

11.10. Galvanization of panel fences, poles and assembly elements will be in accordance with ASTM.A123, ASTM.A153 and TSE 914 standards.

11.11. Faulty or broken panel fences will not be installed and will be replaced with new ones.

11.12. Mounting poles will consist of a 200 cm vertical section and a V section that makes a 45° angle with the horizontal and is at least 30 cm high at a right angle.

11.13. The parts of the poles facing the air will be closed.

11.14. Razor wire will be placed inside the V section.

11.15. Razor wire will be at least 75 cm in diameter and comply with the TSE 8745 military purpose razor wire standard.

11.16. The razor wire will be mounted inside the V header using 3 pieces of 4 mm galvanized tension wire on both sides.

11.17. It will be a 100 cm x 200 cm single wing locked panel door. If necessary, door changes can be made by the Purchaser.

11.18. The doors of all physical security equipment will be able to be opened with a single key.

13. OTHER ISSUES

13.1. A total of 20 programming kits will be given for fixed and mobile radios, and a total of 30 programming kits for handheld radios. (It will be given at the time of delivery)

13.2. 20 pieces of software (CD / USB Flash Drive, etc.) will be given containing the necessary software for programming the radios. (It will be given at the time of delivery)

13.3. The English and/or Turkish user manual containing technical information and explanatory circuit diagrams of the devices will be given in book form upon delivery. (in total, 25 pieces for mobile radio, 25 pieces for handheld radio, 25 pieces for relay radio) (It will be given at the time of delivery)

13.4. If there is any special equipment needed for the repair of radios, 30 of these devices will be provided. (It will be given at the time of delivery)

13.5. The Purchaser shall have the right to make changes to the locations where the systems and devices are planned to be installed, provided that such changes are made within the scope of the project site and that the Purchaser gives reasonable advance notice.

13.6. All software updates, upgrades, and reinstallations will be performed free of charge during the warranty period, and any licenses will be provided free of charge by the Supplier.

13.7. During the warranty period, after any intervention on the devices (including periodic maintenance), the Supplier's engineer/technical personnel shall prepare a technical report in at least two copies and deliver one copy to the relevant unit manager. During the warranty period, the Supplier shall also submit a written report to the relevant Regional Directorate and the Purchaser each year following the installation of the device, detailing the device's malfunctions, interventions performed, periodic maintenance and repairs, the current status of the device, and its installation.

14. TRAINING

14.1. Pre-Technical Training Program: The Supplier shall provide five (5) days of applied training covering the following topics to 50 technical personnel designated by the Purchaser (at regional headquarters or a designated location) prior to acceptance of the system. The Supplier shall be responsible for all costs incurred, excluding accommodation, subsistence, and travel expenses.

- Handheld, Vehicle, and Fixed Radio Training: Device menu structure, programming, battery optimization, vehicle kit installation and removal, antenna and connector checks.

- Relay Radio and Radio Link Training: Relay duplexer and radio link settings,
14.2. Comprehensive Technical Training Program:
- After acceptance of the system, the Supplier shall provide training to 75 technical personnel (at regional headquarters or a designated location) determined by the Purchaser for a total of 20 days: 10 days for Handheld, Vehicle, and Fixed Radios; 3 days for Relay Radios; 5 days for Radio Links; and 2 days for Solar Energy Systems. The practical training will cover topics such as error code analysis, BER measurement, SWR measurements, radio link configurations, troubleshooting, and fault resolution. The Supplier shall be responsible for all costs incurred, excluding accommodation, subsistence, and travel expenses.
14.3. Training Certification
- Personnel who successfully complete the training will be awarded a Certificate approved by the Supplier company.
14.4. Periodical Training
- The supplier shall organize one (1) day of “Periodic Training” once a year during the warranty period for each regional office, covering innovations and issues in the system.

**DRAFT LIST OF LOCATIONS WHERE DIGITAL RADIO COMMUNICATION SYSTEMS
WILL BE INSTALLED KAHRAMANMARAŞ, HATAY, ADANA, MERSİN, ANTALYA,
MUĞLA, İZMİR, BALIKESİR, AND ÇANAKKALE REGIONAL DIRECTORATE OF
FORESTRY**

	REGIONAL DIRECTORATE	DISTRICT DIRECTORATE	North (N)	East (E)	RELAY AND RADIO LINK CONNECTIONS		
1	K.MARAŞ	K.MARAŞ	37 35 23	36 53 58	K.MARAŞ	AHIRDAĞI	1
2	K.MARAŞ	K.MARAŞ	37 37 48	36 52 18	AHIRDAĞI	K.MARAŞ	1
3	K.MARAŞ	K.MARAŞ	37 37 48	36 52 18	AHIRDAĞI	KAVKURT	2
4	K.MARAŞ	ONİKİŞUBAT	37 42 47	36 43 45	KAVKURT	AHIRDAĞI	2
5	K.MARAŞ	K.MARAŞ	37 37 48	36 52 18	AHIRDAĞI	KARTAL	3
6	K.MARAŞ	K.MARAŞ	37 31 05	37 07 08	KARTAL	AHIRDAĞI	3
7	K.MARAŞ	K.MARAŞ	37 31 05	37 07 08	KARTAL	SAKİBABA	4
8	K.MARAŞ	K.MARAŞ	37 37 48	37 17 37	SAKİBABA	KARTAL	4
9	K.MARAŞ	K.MARAŞ	37 31 05	37 07 08	KARTAL	TÜRKOĞLU	5
10	K.MARAŞ	ANDIRIN	37 23 13	36 50 54	TÜRKOĞLU	KARTAL	5
11	K.MARAŞ	K.MARAŞ	37 31 05	37 07 08	KARTAL	DÜLLÜKBABA	6
12	K.MARAŞ	GAZİANTEP	37 07 22	37 18 05	DÜLLÜKBABA	KARTAL	6
13	K.MARAŞ	K.MARAŞ	37 37 48	37 17 37	SAKİBABA	PAZARCIK	7
14	K.MARAŞ	K.MARAŞ	37 29 24	37 17 30	PAZARCIK	SAKİBABA	7
15	K.MARAŞ	ONİKİŞUBAT	37 32 55	36 34 48	BAŞKONUŞ	KAVKURT	8
16	K.MARAŞ	ONİKİŞUBAT	37 42 47	36 43 45	KAVKURT	BAŞKONUŞ	8
17	K.MARAŞ	ONİKİŞUBAT	37 32 55	36 34 48	BAŞKONUŞ	ULUDAZ	9
18	K.MARAŞ	ANDIRIN	37 27 00	36 39 16	ULUDAZ	BAŞKONUŞ	9
19	K.MARAŞ	ONİKİŞUBAT	37 32 55	36 34 48	BAŞKONUŞ	BEREKETLİ	10
20	K.MARAŞ	ANDIRIN	37 23 17	36 27 36	BEREKETLİ	BAŞKONUŞ	10
21	K.MARAŞ	ONİKİŞUBAT	37 32 55	36 34 48	BAŞKONUŞ	KARAYÜCE	11
22	K.MARAŞ	ANDIRIN	37 34 58	36 24 26	KARAYÜCE	BAŞKONUŞ	11
23	K.MARAŞ	ONİKİŞUBAT	37 42 47	36 43 45	KAVKURT	SUÇATI	12
24	K.MARAŞ	ONİKİŞUBAT	37 47 12	36 41 12	SUÇATI	KAVKURT	12
25	K.MARAŞ	GÖKSUN	38 01 40	36 21 52	CENNETYÜCESİ	GÖKSUN	13
26	K.MARAŞ	GÖKSUN	38 01 19	36 29 58	GÖKSUN	CENNETYÜCESİ	13
27	K.MARAŞ	GÖKSUN	38 01 19	36 29 58	GÖKSUN	TAŞOLUK	14
28	K.MARAŞ	GÖKSUN	37 58 46	36 27 55	TAŞOLUK	GÖKSUN	14
29	K.MARAŞ	GÖKSUN	37 58 46	36 27 55	TAŞOLUK	TÜLLÜCE	15
30	K.MARAŞ	GÖKSUN	38 07 46	36 49 25	TÜLLÜCE	TAŞOLUK	15
31	K.MARAŞ	GÖKSUN	37 53 10	36 20 04	KERSEN	TÜLLÜCE	16
32	K.MARAŞ	GÖKSUN	38 07 46	36 49 25	TÜLLÜCE	KERSEN	16
33	K.MARAŞ	GÖKSUN	38 07 46	36 49 25	TÜLLÜCE	EKİNÖZÜ	17
34	K.MARAŞ	GÖKSUN	38 02 57	37 10 51	EKİNÖZÜ	TÜLLÜCE	17
35	K.MARAŞ	GÖKSUN	38 07 46	36 49 25	TÜLLÜCE	YAZIKÖY	18
36	K.MARAŞ	GÖKSUN	38 10 42	36 46 30	YAZIKÖY	TÜLLÜCE	18
37	K.MARAŞ	ANDIRIN	37 34 58	36 24 26	KARAYÜCE	YEŞİLYURT	19
38	K.MARAŞ	ANDIRIN	37 36 55	36 18 28	YEŞİLYURT	KARAYÜCE	19
39	K.MARAŞ	ANDIRIN	37 44 04	36 17 60	TERLİKTEPE	YEŞİLYURT	20
40	K.MARAŞ	ANDIRIN	37 36 55	36 18 28	YEŞİLYURT	TERLİKTEPE	20
41	K.MARAŞ	ANDIRIN	37 36 55	36 18 28	YEŞİLYURT	AVLUK(ADANA)	21
42	ADANA	ADANA	37 31 42	36 11 45	AVLUK(ADANA)	YEŞİLYURT	21
43	HATAY	DÖRTYOL	36 56 13	36 21 41	DAZ KULE	KUZUCULU	22
44	HATAY	DÖRTYOL	36 53 40	36 13 37	KUZUCULU	DAZ KULE	22

45	K.MARAŞ	GAZİANTEP	37 11 50	36 48 04	EMİRTEPE	ULUDAZ	23
46	K.MARAŞ	ANDIRIN	37 27 00	36 39 16	ULUDAZ	EMİRTEPE	23
47	K.MARAŞ	GAZİANTEP	37 11 50	36 48 04	EMİRTEPE	TÜRKOĞLU	24
48	K.MARAŞ	ANDIRIN	37 23 13	36 50 54	TÜRKOĞLU	EMİRTEPE	24
49	K.MARAŞ	GAZİANTEP	37 11 50	36 48 04	EMİRTEPE	NURDAĞI	25
50	K.MARAŞ	GAZİANTEP	37 11 02	36 43 11	NURDAĞI	EMİRTEPE	25
	REGIONAL DIRECTORATE	DISTRICT DIRECTORATE	North (N)	East (E)	RELAY AND RADIO LINK CONNECTIONS		
51	K.MARAŞ	GAZİANTEP	37 11 50	36 48 04	EMİRTEPE	İKİZTEPE	26
52	K.MARAŞ	GAZİANTEP	36 58 17	36 50 10	İKİZTEPE	EMİRTEPE	26
53	K.MARAŞ	GAZİANTEP	36 58 17	36 50 10	İKİZTEPE	ISLAHİYE	27
54	K.MARAŞ	GAZİANTEP	37 01 32	36 37 60	ISLAHİYE	İKİZTEPE	27
55	K.MARAŞ	GAZİANTEP	36 58 17	36 50 10	İKİZTEPE	BAĞLARÜSTÜ	28
56	K.MARAŞ	GAZİANTEP	36 57 29	36 35 15	BAĞLARÜSTÜ	İKİZTEPE	28
57	HATAY	DÖRTYOL	36 49 47	36 10 07	RECAİ DOĞAN	KUZUCULU	29
58	HATAY	DÖRTYOL	36 53 40	36 13 37	KUZUCULU	RECAİ DOĞAN	29
59	HATAY	DÖRTYOL	36 49 47	36 10 07	RECAİ DOĞAN	KARAKESE	30
60	HATAY	DÖRTYOL	36 48 48	36 14 56	KARAKESE	RECAİ DOĞAN	30
61	HATAY	DÖRTYOL	36 49 47	36 10 07	RECAİ DOĞAN	ÇOBANDEDE	31
62	HATAY	İSKENDERUN	36 31 08	36 15 20	ÇOBANDEDE	RECAİ DOĞAN	31
63	HATAY	DÖRTYOL	36 53 40	36 13 37	KUZUCULU	TOHTAK YAYLASI	32
64	HATAY	DÖRTYOL	36 51 53	36 24 27	TOHTAK YAYLASI	KUZUCULU	32
65	HATAY	İSKENDERUN	36 31 08	36 15 20	ÇOBANDEDE	HACIARASLI	33
66	HATAY	İSKENDERUN	36 28 60	36 26 14	HACIARASLI	ÇOBANDEDE	33
67	HATAY	İSKENDERUN	36 31 08	36 15 20	ÇOBANDEDE	İSKENDERUN	34
68	HATAY	İSKENDERUN	36 35 04	36 11 09	İSKENDERUN	ÇOBANDEDE	34
69	HATAY	İSKENDERUN	36 31 08	36 15 20	ÇOBANDEDE	SARIMAZI	35
70	HATAY	İSKENDERUN	36 31 17	36 09 40	SARIMAZI	ÇOBANDEDE	35
71	HATAY	İSKENDERUN	36 31 08	36 15 20	ÇOBANDEDE	PİRİNÇLİK	36
72	HATAY	İSKENDERUN	36 31 07	36 02 45	PİRİNÇLİK	ÇOBANDEDE	36
73	HATAY	İSKENDERUN	36 31 08	36 15 20	ÇOBANDEDE	KALE KULE	37
74	HATAY	ANTAKYA	36 11 58	36 10 42	KALE KULE	ÇOBANDEDE	37
75	HATAY	İSKENDERUN	36 31 08	36 15 20	ÇOBANDEDE	SAHİL DEPO	38
76	HATAY	İSKENDERUN	36 27 08	35 56 56	SAHİL DEPO	ÇOBANDEDE	38
77	HATAY	İSKENDERUN	36 28 60	36 26 14	HACIARASLI	KALE KULE	39
78	HATAY	ANTAKYA	36 11 58	36 10 42	KALE KULE	HACIARASLI	39
79	HATAY	İSKENDERUN	36 27 08	35 56 56	SAHİL DEPO	KONACIK	40
80	HATAY	İSKENDERUN	36 21 35	35 50 10	KONACIK	SAHİL DEPO	40
81	HATAY	İSKENDERUN	36 27 08	35 56 56	SAHİL DEPO	KİSECİK RADAR	41
82	HATAY	İSKENDERUN	36 18 13	36 00 18	KİSECİK RADAR	SAHİL DEPO	41
83	HATAY	İSKENDERUN	36 18 13	36 00 18	KİSECİK RADAR	KALE KULE	42
84	HATAY	ANTAKYA	36 11 58	36 10 42	KALE KULE	KİSECİK RADAR	42
85	HATAY	İSKENDERUN	36 18 13	36 00 18	KİSECİK RADAR	BALLİÖZ	43
86	HATAY	İSKENDERUN	36 15 13	36 03 40	BALLİÖZ	KİSECİK RADAR	43
87	HATAY	ANTAKYA	36 11 58	36 10 42	KALE KULE	MUSADAĞ	44
88	HATAY	ANTAKYA	36 11 17	35 56 03	MUSADAĞ	KALE KULE	44
89	HATAY	ANTAKYA	36 11 58	36 10 42	KALE KULE	SAMANDAĞ	45
90	HATAY	ANTAKYA	36 09 50	35 59 38	SAMANDAĞ	KALE KULE	45
91	HATAY	ANTAKYA	36 11 58	36 10 42	KALE KULE	GÜLDEREN	46
92	HATAY	ANTAKYA	36 17 31	36 07 11	GÜLDEREN	KALE KULE	46
93	HATAY	ANTAKYA	36 11 58	36 10 42	KALE KULE	D23	47

94	HATAY	ANTAKYA	36 00 45	36 03 22	D23	KALE KULE	47
95	HATAY	ANTAKYA	36 00 45	36 03 22	D23	ÇABALA	48
96	HATAY	ANTAKYA	35 53 57	36 06 16	ÇABALA	D23	48
97	HATAY	KİLİS	36 49 31	36 45 33	ÖMERDEDE	KARŞIYAKA	49
98	HATAY	KİLİS	36 48 11	36 31 16	KARŞIYAKA	ÖMERDEDE	49
99	ANTALYA	KAŞ	36 22 44	29 26 31	DUMANDAĞ	AVDANCIK-(MUĞLA)	50
100	MUĞLA	SKEMER	36 23 03	29 11 23	AVDANCIK	DUMANDAĞ- ANTALYA	50
101	ANTALYA	GAZİPAŞA	36 12 55	32 31 25	KARATEPE	İRBİ-(MERSİN)	51
102	MERSİN	ANAMUR	36 04 18	32 43 09	İRBİ	KARATEPE-ANTALYA	51
103	MERSİN	TARSUS	36 57 43	34 48 00	DEDELER	TRCELL SALBAŞ- (ADANA)	52
104	ADANA	ADANA	37 05 19	35 07 21	TRCELL SALBAŞ	DEDELER-(MERSİN)	52
	REGIONAL DIRECTORATE	DISTRICT DIRECTORATE	North (N)	East (E)	RELAY AND RADIO LINK CONNECTIONS		
105	ADANA	ADANA	37 01 39	36 00 22	AZİZLİ	RECAİDOĞAN- (HATAY)	53
106	HATAY	İSKENDERUN	36 49 47	36 10 07	RECAİDOĞAN	AZİZLİ-(ADANA)	53
107	MUĞLA	AYDIN	37 39 43	28 06 21	AYBELEN	PAŞAYAYLASI	54
108	MUĞLA	AYDIN	37 57 10	27 53 56	PAŞAYAYLASI	AYBELEN	54
109	MUĞLA	AYDIN	37 39 43	28 06 21	AYBELEN	KÜÇÜKMADRAN	55
110	MUĞLA	NAZİLLİ	37 42 32	28 15 17	KÜÇÜKMADRAN	AYBELEN	55
111	MUĞLA	AYDIN	37 57 10	27 53 56	AYDIN	PAŞAYAYLASI	56
112	MUĞLA	AYDIN	37 57 10	27 53 56	PAŞAYAYLASI	AYDIN	56
113	MUĞLA	AYDIN	37 28 26	28 00 00	GÖKBEL	ERENTEPE-YATAĞAN	57
114	MUĞLA	YATAĞAN	37 21 53	28 07 51	ERENTEPE-YATAĞAN	GÖKBEL	57
115	MUĞLA	AYDIN	37 49 19	27 25 00	GÜMÜŞDAĞ	YAREN	58
116	MUĞLA	AYDIN	37 45 00	27 45 00	YAREN	GÜMÜŞDAĞ	58
117	MUĞLA	AYDIN	37 49 19	27 25 00	GÜMÜŞDAĞ	KARAOLUK	59
118	MUĞLA	AYDIN	37 40 57	27 16 49	KARAOLUK	GÜMÜŞDAĞ	59
119	MUĞLA	AYDIN	37 49 19	27 25 00	GÜMÜŞDAĞ	PAŞAYAYLASI	60
120	MUĞLA	AYDIN	37 57 10	27 53 56	PAŞAYAYLASI	GÜMÜŞDAĞ	60
121	MUĞLA	AYDIN	37 40 57	27 16 49	KARAOLUK	İLBİRA	61
122	MUĞLA	MİLAS	37 23 21	27 32 44	İLBİRA	KARAOLUK	61
123	MUĞLA	DALAMAN	36 52 07	29 01 45	AYGIR	BUYANCIK	62
124	MUĞLA	KÖYCEĞİZ	36 57 41	28 54 10	BUYANCIK	AYGIR	62
125	MUĞLA	DALAMAN	36 52 07	29 01 45	AYGIR	ÇALDAĞI	63
126	MUĞLA	FETHİYE	36 51 55	29 07 05	ÇALDAĞI	AYGIR	63
127	MUĞLA	DALAMAN	36 47 20	28 48 27	DALAMAN	NURİBABA	64
128	MUĞLA	DALAMAN	36 51 34	28 50 58	NURİBABA	DALAMAN	64
129	MUĞLA	DALAMAN	36 51 34	28 50 58	NURİBABA	DİKMENTEPE	65
130	MUĞLA	FETHİYE	36 47 55	29 00 15	DİKMENTEPE	NURİBABA	65
131	MUĞLA	DALAMAN	36 51 34	28 50 58	NURİBABA	ÖLEMEZ	66
132	MUĞLA	KÖYCEĞİZ	36 51 47	28 35 10	ÖLEMEZ	NURİBABA	66
133	MUĞLA	FETHİYE	36 31 48	29 10 51	BABADAĞ	AVDANCIK	67
134	MUĞLA	SKEMER	36 23 03	29 11 23	AVDANCIK	BABADAĞ	67
135	MUĞLA	FETHİYE	36 31 48	29 10 51	BABADAĞ	FETHİYE	68
136	MUĞLA	FETHİYE	36 37 20	29 07 18	FETHİYE	BABADAĞ	68
137	MUĞLA	FETHİYE	36 31 48	29 10 51	BABADAĞ	DİKMENTEPE	69
138	MUĞLA	FETHİYE	36 47 55	29 00 15	DİKMENTEPE	BABADAĞ	69

139	MUĞLA	FETHİYE	36 51 55	29 07 05	ÇALDAĞI	GEYRANDAĞI	70
140	MUĞLA	FETHİYE	36 45 02	29 15 28	GEYRANDAĞ	ÇALDAĞI	70
141	MUĞLA	FETHİYE	36 45 02	29 15 28	GEYRANDAĞ	SEYDİKEMER	71
142	MUĞLA	SKEMER	36 38 44	29 22 11	SEYDİKEMER	GEYRANDAĞ	71
143	MUĞLA	FETHİYE	36 45 02	29 15 28	GEYRANDAĞ	ERENTEPE-S.KEMER	72
144	MUĞLA	SKEMER	36 38 20	29 29 54	ERENTEPE-S.KEMER	GEYRANDAĞ	72
145	MUĞLA	KAVAKLIDERE	37 20 34	28 22 20	GÖKTEPE	KORIŞ-BABADAĞ2	73
146	MUĞLA	KAVAKLIDERE	37 29 08	28 28 27	KORIŞ-BABADAĞ2	GÖKTEPE	73
147	MUĞLA	KAVAKLIDERE	37 20 34	28 22 20	GÖKTEPE	ALTINÇAMTEPE	74
148	MUĞLA	YILANLI	37 20 18	28 31 02	ALTINÇAMTEPE	GÖKTEPE	74
149	MUĞLA	KAVAKLIDERE	37 26 40	28 21 31	KAVAKLIDERE	SODRA	75
150	MUĞLA	KAVAKLIDERE	37 28 30	28 18 44	SODRA	KAVAKLIDERE	75
151	MUĞLA	KAVAKLIDERE	37 29 08	28 28 27	KORIŞ-BABADAĞ2	SODRA	76
152	MUĞLA	KAVAKLIDERE	37 28 30	28 18 44	SODRA	KORIŞ-BABADAĞ2	76
153	MUĞLA	KAVAKLIDERE	37 28 30	28 18 44	SODRA	ERİÇEK	77
154	MUĞLA	NAZİLLİ	37 32 54	28 24 12	ERİÇEK	SODRA	77
155	MUĞLA	KÖYCEĞİZ	36 57 41	28 54 10	BUYANCIK	KEPEZ	78
156	MUĞLA	KÖYCEĞİZ	37 02 24	28 59 27	KEPEZ	BUYANCIK	78
157	MUĞLA	KÖYCEĞİZ	37 02 08	28 48 16	ÇİÇEKBABA	GÖKTAŞ	79
158	MUĞLA	MUĞLA	37 06 05	28 33 36	GÖKTAŞ	ÇİÇEKBABA	79
159	MUĞLA	KÖYCEĞİZ	37 02 08	28 48 16	ÇİÇEKBABA	KEPEZ	80
	REGIONAL DIRECTORATE	DISTRICT DIRECTORATE	North (N)	East (E)	RELAY AND RADIO LINK CONNECTIONS		
160	MUĞLA	KÖYCEĞİZ	37 02 24	28 59 27	KEPEZ	ÇİÇEKBABA	80
161	MUĞLA	KÖYCEĞİZ	36 54 24	28 30 50	KANDİL	ÖLEMEZ	81
162	MUĞLA	KÖYCEĞİZ	36 51 47	28 35 10	ÖLEMEZ	KANDİL	81
163	MUĞLA	KÖYCEĞİZ	36 57 40	28 41 17	KÖYCEĞİZ	ÖLEMEZ	82
164	MUĞLA	KÖYCEĞİZ	36 51 47	28 35 10	ÖLEMEZ	KÖYCEĞİZ	82
165	MUĞLA	KÖYCEĞİZ	36 51 47	28 35 10	ÖLEMEZ	PALAMUT	83
166	MUĞLA	MARMARİS	36 45 22	28 12 59	PALAMUT	ÖLEMEZ	83
167	MUĞLA	MARMARİS	36 53 21	28 19 38	BALANDAĞI	ALTINSİVRİ	84
168	MUĞLA	MARMARİS	36 55 48	28 15 15	ALTINSİVRİ	BALANDAĞI	84
169	MUĞLA	MARMARİS	36 55 48	28 15 15	ALTINSİVRİ	KOVALICA	85
170	MUĞLA	MARMARİS	36 46 37	27 57 37	KOVALICA	ALTINSİVRİ	85
171	MUĞLA	MARMARİS	36 55 48	28 15 15	ALTINSİVRİ	ÇÖKERTME	86
172	MUĞLA	MİLAS	37 02 23	27 59 17	ÇÖKERTME	ALTINSİVRİ	86
173	MUĞLA	MARMARİS	36 46 37	27 57 37	KOVALICA	PALAMUT	87
174	MUĞLA	MARMARİS	36 45 22	28 12 59	PALAMUT	KOVALICA	87
175	MUĞLA	MARMARİS	36 46 37	27 57 37	KOVALICA	RADARI-DATÇA	88
176	MUĞLA	MARMARİS	36 43 52	27 34 56	RADARI-DATÇA	KOVALICA	88
177	MUĞLA	MARMARİS	36 51 10	28 16 02	MARMARİS	PALAMUT	89
178	MUĞLA	MARMARİS	36 45 22	28 12 59	PALAMUT	MARMARİS	89
179	MUĞLA	MİLAS	37 19 57	27 56 22	AKSİVRİ	MİLAS	90
180	MUĞLA	MİLAS	37 18 24	27 46 50	MİLAS	AKSİVRİ	90
181	MUĞLA	MİLAS	37 19 57	27 56 22	AKSİVRİ	ILBIRA	91
182	MUĞLA	MİLAS	37 23 21	27 32 44	ILBIRA	AKSİVRİ	91
183	MUĞLA	MİLAS	37 19 57	27 56 22	AKSİVRİ	KARTAL	92
184	MUĞLA	MİLAS	37 11 35	27 57 38	KARTAL	AKSİVRİ	92
185	MUĞLA	MİLAS	37 02 23	27 59 17	ÇÖKERTME	KARADAĞ-MİLAS	93
186	MUĞLA	MİLAS	37 06 20	27 52 19	KARADAĞ-MİLAS	ÇÖKERTME	93
187	MUĞLA	MİLAS	37 02 39	27 35 43	KALEDAĞ	KARADAĞ-MİLAS	94

188	MUĞLA	MİLAS	37 06 20	27 52 19	KARADAĞ-MİLAS	KALEDAĞ	94
189	MUĞLA	MİLAS	37 02 39	27 35 43	KALEDAĞ	KAYABAŞI-BODRUM	95
190	MUĞLA	MİLAS	37 03 55	27 26 31	KAYABAŞI-BODRUM	KALEDAĞ	95
191	MUĞLA	MİLAS	37 11 35	27 57 38	KARTAL	KARADAĞ-MİLAS	96
192	MUĞLA	MİLAS	37 06 20	27 52 19	KARADAĞ-MİLAS	KARTAL	96
193	MUĞLA	MİLAS	37 09 52	28 02 08	KAVAKDAĞ	MARÇALI	97
194	MUĞLA	MUĞLA	37 09 08	28 08 45	MARÇALI	KAVAKDAĞ	97
195	MUĞLA	MİLAS	37 09 52	28 02 08	KAVAKDAĞ	BENCİKDAĞI	98
196	MUĞLA	YATAĞAN	37 14 08	28 02 52	BENCİKDAĞI	KAVAKDAĞ	98
197	MUĞLA	MUĞLA	37 06 05	28 33 36	GÖKTAŞ	SAKARTEPE	99
198	MUĞLA	MUĞLA	37 04 12	28 20 23	SAKARTEPE	GÖKTAŞ	99
199	MUĞLA	MUĞLA	37 06 05	28 33 36	GÖKTAŞ	ALATAŞ	100
200	MUĞLA	YILANLI	37 07 43	28 41 33	ALATAŞ	GÖKTAŞ	100
201	MUĞLA	MUĞLA	37 09 08	28 08 45	MARÇALI	KURDU	101
202	MUĞLA	YILANLI	37 12 08	28 28 35	KURDU	MARÇALI	101
203	MUĞLA	MUĞLA	37 12 43	28 21 57	MUĞLA	KURDU	102
204	MUĞLA	YILANLI	37 12 08	28 28 35	KURDU	MUĞLA	102
205	MUĞLA	MUĞLA	37 04 12	28 20 23	SAKARTEPE	KURDU	103
206	MUĞLA	YILANLI	37 12 08	28 28 35	KURDU	SAKARTEPE	103
207	MUĞLA	NAZİLLİ	37 32 54	28 24 12	ERİCEK	KARAGEDİK	104
208	MUĞLA	NAZİLLİ	37 34 45	28 19 08	KARAGEDİK	ERİCEK	104
209	MUĞLA	NAZİLLİ	38 02 36	28 33 47	KAPLANGER	KARADAĞ-Nazilli	105
210	MUĞLA	NAZİLLİ	37 58 29	28 29 19	KARADAĞ-Nazilli	KAPLANGER	105
211	MUĞLA	NAZİLLİ	37 49 38	28 40 04	KARACAÖREN	KARADAĞ-Nazilli	106
212	MUĞLA	NAZİLLİ	37 58 29	28 29 19	KARADAĞ-Nazilli	KARACAÖREN	106
213	MUĞLA	NAZİLLİ	37 49 38	28 40 04	KARACAÖREN	KARLIK	107
214	MUĞLA	NAZİLLİ	37 41 50	28 32 56	KARLIK	KARACAÖREN	107
	REGIONAL DIRECTORATE	DISTRICT DIRECTORATE	North (N)	East (E)	RELAY AND RADIO LINK CONNECTIONS		
215	MUĞLA	NAZİLLİ	37 49 38	28 40 04	KARACAÖREN	ERENTEPE (DENİZLİ)	108
216	DENİZLİ	DENİZLİ	37 51 46	28 45 30	ERENTEPE-(DENİZLİ)	KARACAÖREN	108
217	MUĞLA	NAZİLLİ	37 51 46	28 45 31	ERENTEPE-(DENİZLİ)	BUHARKENT	109
218	MUĞLA	NAZİLLİ	37 58 08	28 44 40	BUHARKENT	ERENTEPE-(DENİZLİ)	109
219	MUĞLA	NAZİLLİ	37 58 29	28 29 19	KARADAĞ-Nazilli	NAZİLLİ	110
220	MUĞLA	NAZİLLİ	37 54 55	28 20 00	NAZİLLİ	KARADAĞ-Nazilli	110
221	MUĞLA	NAZİLLİ	37 58 29	28 29 19	KARADAĞ-Nazilli	KÜÇÜKMADRAN	111
222	MUĞLA	NAZİLLİ	37 42 32	28 15 17	KÜÇÜKMADRAN	KARADAĞ-Nazilli	111
223	MUĞLA	NAZİLLİ	37 34 45	28 19 08	KARAGEDİK	KARLIK	112
224	MUĞLA	NAZİLLİ	37 41 50	28 32 56	KARLIK	KARAGEDİK	112
225	MUĞLA	NAZİLLİ	37 41 50	28 32 56	KARLIK	DEDEBELEN	113
226	MUĞLA	NAZİLLİ	37 45 30	28 27 51	DEDEBELEN	KARLIK	113
227	MUĞLA	SKEMER	36 48 31	29 28 38	AKDÜMEN	ERENTEPE-KEMER	114
228	MUĞLA	SKEMER	36 38 20	29 29 54	ERENTEPE-KEMER	AKDÜMEN	114
229	MUĞLA	SKEMER	36 23 03	29 11 23	AVDANCIK	ERENTEPE-KEMER	115
230	MUĞLA	SKEMER	36 38 20	29 29 54	ERENTEPE-KEMER	AVDANCIK	115
231	MUĞLA	YATAĞAN	37 14 08	28 02 52	BENCİKDAĞI	ERENTEPE-YATAĞAN	116
232	MUĞLA	YATAĞAN	37 21 53	28 07 51	ERENTEPE-YATAĞAN	BENCİKDAĞI	116
233	MUĞLA	YATAĞAN	37 21 53	28 07 51	ERENTEPE-YATAĞAN	YATAĞAN	117
234	MUĞLA	YATAĞAN	37 20 29	28 08 09	YATAĞAN	ERENTEPE-YATAĞAN	117

235	MUĞLA	YILANLI	37 20 18	28 31 02	ALTIÇAMTEPE	KIZILKAYA	118
236	MUĞLA	YILANLI	37 19 58	28 39 47	KIZILKAYA	ALTIÇAMTEPE	118
237	MUĞLA	YILANLI	37 19 58	28 39 47	KIZILKAYA	SARNIÇTEPE	119
238	MUĞLA	YILANLI	37 13 55	28 39 16	SARNIÇTEPE	KIZILKAYA	119
239	MUĞLA	YILANLI	37 07 43	28 41 33	ALATAŞ	SARNIÇTEPE	120
240	MUĞLA	YILANLI	37 13 55	28 39 16	SARNIÇTEPE	ALATAŞ	120
241	İZMİR	AKHİSAR	38 55 45	27 35 34	ADATEPE	AKHİSAR	121
242	İZMİR	AKHİSAR	38 55 45	27 35 34	AKHİSAR	ADATEPE	121
243	İZMİR	AKHİSAR	38 48 01	27 59 13	AKÇAALAN	AYSEKİZ	122
244	İZMİR	MANİSA	38 37 46	27 46 00	AYSEKİZ	AKÇAALAN	122
245	İZMİR	AKHİSAR	38 59 50	27 53 43	DİNGİLLER	KARADAĞ	123
246	İZMİR	AKHİSAR	39 01 38	28 00 27	KARADAĞ	DİNGİLLER	123
247	İZMİR	AKHİSAR	38 59 50	27 53 43	DİNGİLLER	KAYGANLI	124
248	İZMİR	AKHİSAR	39 07 31	27 59 53	KAYGANLI	DİNGİLLER	124
249	İZMİR	AKHİSAR	38 59 50	27 53 43	DİNGİLLER	ADATEPE	125
250	İZMİR	AKHİSAR	38 55 45	27 35 34	ADATEPE	DİNGİLLER	125
251	İZMİR	AKHİSAR	38 59 50	27 53 43	DİNGİLLER	SİLEDİK	126
252	İZMİR	SOMA	39 09 25	27 46 59	SİLEDİK	DİNGİLLER	126
253	İZMİR	AKHİSAR	39 01 38	28 00 27	KARADAĞ	ÖRENCİK	127
254	İZMİR	GÖRDES	38 58 36	28 13 24	ÖRENCİK	KARADAĞ	127
255	İZMİR	BAYINDIR	38 04 33	27 37 11	ALİYAĞBASAN	BASRA	128
256	İZMİR	BAYINDIR	38 14 22	27 38 55	BASRA	ALİYAĞBASAN	128
257	İZMİR	BAYINDIR	38 14 22	27 38 55	BASRA	KARLIK	129
258	İZMİR	BAYINDIR	35 15 52	27 31 09	KARLIK	BASRA	129
259	İZMİR	BAYINDIR	38 14 22	27 38 55	BASRA	BAYINDIR	130
260	İZMİR	BAYINDIR	38 13 16	27 38 56	BAYINDIR	BASRA	130
261	İZMİR	BAYINDIR	38 14 22	27 38 55	BASRA	ÇINGIRAK	131
262	İZMİR	BAYINDIR	38 17 38	27 48 06	ÇINGIRAK	BASRA	131
263	İZMİR	BAYINDIR	38 20 18	27 38 37	ÇALDEDE	MAHMUTDAĞI	132
264	İZMİR	İZMİR	38 20 51	27 30 15	MAHMUTDAĞI	ÇALDEDE	132
265	İZMİR	BAYINDIR	38 17 38	27 48 06	ÇINGIRAK	KELDAĞ	133
266	İZMİR	BAYINDIR	38 18 50	27 53 18	KELDAĞ	ÇINGIRAK	133
267	İZMİR	BAYINDIR	38 20 31	28 00 56	GÖLCÜK	KELDAĞ	134
268	İZMİR	BAYINDIR	38 18 50	27 53 18	KELDAĞ	GÖLCÜK	134
269	İZMİR	BAYINDIR	38 20 31	28 00 56	GÖLCÜK	KARTAL	135
	REGIONAL DIRECTORATE	DISTRICT DIRECTORATE	North (N)	East (E)	RELAY AND RADIO LINK CONNECTIONS		
270	İZMİR	BAYINDIR	38 21 02	27 54 39	KARTAL	GÖLCÜK	135
271	İZMİR	BAYINDIR	38 20 31	28 00 56	GÖLCÜK	OYUKBABA	136
272	İZMİR	BAYINDIR	38 03 14	28 18 36	OYUKBABA	GÖLCÜK	136
273	İZMİR	BAYINDIR	37 58 04	27 27 51	GÖRÜNMEZ	MERYEMANA	137
274	İZMİR	BAYINDIR	37 54 47	27 20 18	MERYEMANA	GÖRÜNMEZ	137
275	İZMİR	BAYINDIR	38 18 12	27 35 15	HAVUZLU	MAHMUTDAĞI	138
276	İZMİR	İZMİR	38 20 51	27 30 15	MAHMUTDAĞI	HAVUZLU	138
277	İZMİR	BAYINDIR	38 18 12	27 35 15	HAVUZLU	KARLIK	139
278	İZMİR	BAYINDIR	38 15 52	27 31 09	KARLIK	HAVUZLU	139
279	İZMİR	BAYINDIR	38 21 02	27 54 39	KARTAL	ÇALDAĞ	140
280	İZMİR	MANİSA	38 24 54	27 54 26	ÇALDAĞ	KARTAL	140
281	İZMİR	BAYINDIR	37 54 47	27 20 18	MERYEMANA	DEDEDAĞI	141
282	İZMİR	GAZİEMİR	38 02 56	27 08 41	DEDEDAĞI	MERYEMANA	141
283	İZMİR	BAYINDIR	37 54 47	27 20 18	MERYEMANA	GÜMÜŞDAĞ	142

284	MUĞLA	AYDIN	37 49 19	27 25 00	GÜMÜŞDAĞ(MUĞLA)	MERYEMANA	142
285	İZMİR	BAYINDIR	38 03 14	28 18 36	OYUKBABA	TEKKE	143
286	İZMİR	BAYINDIR	38 15 05	28 21 26	TEKKE	OYUKBABA	143
287	İZMİR	BAYINDIR	38 03 14	28 18 36	OYUKBABA	DEDEBELEN	144
288	MUĞLA	NAZİLLİ	37 45 30	28 27 51	DEDEBELEN	OYUKBABA	144
289	İZMİR	BERGAMA	39 06 53	27 10 33	BERGAMA	KALE	145
290	İZMİR	BERGAMA	39 07 59	27 11 02	KALE	BERGAMA	145
291	İZMİR	BERGAMA	39 03 41	27 30 21	FULA	KODUKBURUN	146
292	İZMİR	BERGAMA	39 02 55	27 21 27	KODUKBURUN	FULA	146
293	İZMİR	BERGAMA	39 09 00	27 04 17	GEYİKLİ	KALE	147
294	İZMİR	BERGAMA	39 07 59	27 11 02	KALE	GEYİKLİ	147
295	İZMİR	BERGAMA	39 09 00	27 04 17	GEYİKLİ	KESMELİ	148
296	İZMİR	BERGAMA	39 13 27	27 04 04	KESMELİ	GEYİKLİ	148
297	İZMİR	BERGAMA	39 17 03	27 24 24	GÖRENTEPE	BOZTEPE	149
298	İZMİR	SOMA	39 18 48	27 29 11	BOZTEPE	GÖRENTEPE	149
299	İZMİR	BERGAMA	39 17 03	27 24 24	GÖRENTEPE	MADRA	150
300	İZMİR	BERGAMA	39 20 58	27 17 07	MADRA	GÖRENTEPE	150
301	İZMİR	BERGAMA	39 07 59	27 11 02	KALE	KODUKBURUN	151
302	İZMİR	BERGAMA	39 02 55	27 21 27	KODUKBURUN	KALE	151
303	İZMİR	BERGAMA	39 07 59	27 11 02	KALE	KAZANDAĞ	152
304	İZMİR	BERGAMA	38 59 48	27 06 16	KAZANDAĞ	KALE	152
305	İZMİR	BERGAMA	38 59 48	27 06 16	KAZANDAĞ	ŞAPHANE	153
306	İZMİR	İZMİR	38 43 20	26 51 14	ŞAPHANE	KAZANDAĞ	153
307	İZMİR	BERGAMA	39 13 27	27 04 04	KESMELİ	KESTEL	154
308	İZMİR	BERGAMA	39 12 14	26 57 24	KESTEL	KESMELİ	154
309	İZMİR	DEMİRCİ	38 55 43	28 37 31	ASTEPE	TÜRKMEN	155
310	İZMİR	GÖRDES	39 05 43	28 32 10	TÜRKMEN	ASTEPE	155
311	İZMİR	DEMİRCİ	38 55 43	28 37 31	ASTEPE	ZİYARET	156
312	İZMİR	DEMİRCİ	39 04 15	28 54 45	ZİYARET	ASTEPE	156
313	İZMİR	DEMİRCİ	38 55 43	28 37 31	ASTEPE	BAYRAKTEPE	157
314	İZMİR	DEMİRCİ	38 50 42	28 51 04	BAYRAKTEPE	ASTEPE	157
315	İZMİR	DEMİRCİ	38 55 43	28 37 31	ASTEPE	KARTALTEPE	158
316	İZMİR	GÖRDES	38 57 23	28 24 58	KARTALTEPE	ASTEPE	158
317	İZMİR	DEMİRCİ	38 50 42	28 51 04	BAYRAKTEPE	DİRGENTEPE	159
318	İZMİR	SALİHLİ	38 38 00	28 37 15	DİRGENTEPE	BAYRAKTEPE	159
319	İZMİR	DEMİRCİ	39 02 59	28 39 41	DEMİRCİ	TÜRKMEN	160
320	İZMİR	GÖRDES	39 05 43	28 32 10	TÜRKMEN	DEMİRCİ	160
321	İZMİR	GAZİEMİR	38 32 28	26 24 49	AKDAĞ	ULAŞTIRAN	161
322	İZMİR	GAZİEMİR	38 15 38	26 34 35	ULAŞTIRAN	AKDAĞ	161
323	İZMİR	GAZİEMİR	38 03 47	27 05 25	AKKAYA	DİKMEN	162
324	İZMİR	GAZİEMİR	38 10 29	26 59 02	DİKMEN	AKKAYA	162
	REGIONAL DIRECTORATE	DISTRICT DIRECTORATE	North (N)	East (E)	RELAY AND RADIO LINK CONNECTIONS		
325	İZMİR	GAZİEMİR	38 03 47	27 05 25	AKKAYA	DEDEDAĞI	163
326	İZMİR	GAZİEMİR	38 02 56	27 08 41	DEDEDAĞI	AKKAYA	163
327	İZMİR	GAZİEMİR	38 18 44	26 47 46	BELENTEPE	ULAŞTIRAN	164
328	İZMİR	GAZİEMİR	38 15 38	26 34 35	ULAŞTIRAN	BELENTEPE	164
329	İZMİR	GAZİEMİR	38 18 44	26 47 46	BELENTEPE	ÇATALKAYA	165
330	İZMİR	GAZİEMİR	38 21 40	26 58 26	ÇATALKAYA	BELENTEPE	165

331	İZMİR	GAZİEMİR	38 21 40	26 58 26	ÇATALKAYA	TEKKETEPE	166
332	İZMİR	GAZİEMİR	38 18 48	27 01 29	TEKKETEPE	ÇATALKAYA	166
333	İZMİR	GAZİEMİR	38 10 29	26 59 02	DİKMEN	ULAŞTIRAN	167
334	İZMİR	GAZİEMİR	38 15 38	26 34 35	ULAŞTIRAN	DİKMEN	167
335	İZMİR	GAZİEMİR	38 18 48	27 01 29	TEKKETEPE	YAMANLAR	168
336	İZMİR	İZMİR	38 33 08	27 09 27	YAMANLAR	TEKKETEPE	168
337	İZMİR	GÖRDES	38 52 03	28 08 27	AZİMDAĞ	ALLAHDİYEN	169
338	İZMİR	SALİHLİ	38 26 36	28 05 32	ALLAHDİYEN	AZİMDAĞ	169
339	İZMİR	GÖRDES	38 52 03	28 08 27	AZİMDAĞ	ÖRENCİK	170
340	İZMİR	GÖRDES	38 58 36	28 13 24	ÖRENCİK	AZİMDAĞ	170
341	İZMİR	GÖRDES	38 48 38	28 04 14	GEDİKKİR	ALLAHDİYEN	171
342	İZMİR	SALİHLİ	38 26 36	28 05 32	ALLAHDİYEN	GEDİKKİR	171
343	İZMİR	GÖRDES	39 03 50	28 17 07	GÖKSEKİ	ÖRENCİK	172
344	İZMİR	GÖRDES	38 58 36	28 13 24	ÖRENCİK	GÖKSEKİ	172
345	İZMİR	GÖRDES	39 03 50	28 17 07	GÖKSEKİ	TÜRKMEN	173
346	İZMİR	GÖRDES	39 05 43	28 32 10	TÜRKMEN	GÖKSEKİ	173
347	İZMİR	GÖRDES	38 56 17	28 16 54	GÖRDES	ÖRENCİK	174
348	İZMİR	GÖRDES	38 58 36	28 13 24	ÖRENCİK	GÖRDES	174
349	BALIKESİR		39 04 50	28 16 24	GÖKSEKİ(Balıkesir)	GÖKSEKİ	175
350	İZMİR	GÖRDES	39 03 50	28 17 07	GÖKSEKİ	GÖKSEKİ(Balıkesir)	175
351	İZMİR	GÖRDES	38 57 23	28 24 58	KARTALTEPE	ÖRENCİK	176
352	İZMİR	GÖRDES	38 58 36	28 13 24	ÖRENCİK	KARTALTEPE	176
353	İZMİR	İZMİR	38 27 12	27 06 32	İZMİR BLG. MDLĞ.	YAMANLAR	177
354	İZMİR	İZMİR	38 33 08	27 09 27	YAMANLAR	İZMİR BLG. MDLĞ.	177
355	İZMİR	İZMİR	38 29 16	27 30 21	MANAS	NİF	178
356	İZMİR	İZMİR	38 23 17	27 21 24	NİF	MANAS	178
357	İZMİR	İZMİR	38 23 17	27 21 24	NİF	YAMANLAR	179
358	İZMİR	İZMİR	38 33 08	27 09 27	YAMANLAR	NİF	179
359	İZMİR	İZMİR	38 23 17	27 21 24	NİF	MANİSADAĞI	180
360	İZMİR	MANİSA	38 34 01	27 27 19	MANİSADAĞI	NİF	180
361	İZMİR	İZMİR	38 43 20	26 51 14	ŞAPHANE	YAMANLAR	181
362	İZMİR	İZMİR	38 33 08	27 09 27	YAMANLAR	ŞAPHANE	181
363	İZMİR	İZMİR	38 33 08	27 09 27	YAMANLAR	ÇAKMAK	182
364	İZMİR	MANİSA	38 42 28	28 15 08	ÇAKMAK	YAMANLAR	182
365	İZMİR	MANİSA	38 37 46	27 46 00	AYSEKİZ	MANİSADAĞI	183
366	İZMİR	MANİSA	38 34 01	27 27 19	MANİSADAĞI	AYSEKİZ	183
367	İZMİR	MANİSA	38 37 46	27 46 00	AYSEKİZ	MİDİLLİ	184
368	İZMİR	MANİSA	38 23 58	27 48 47	MİDİLLİ	AYSEKİZ	184
369	İZMİR	MANİSA	38 37 46	27 46 00	AYSEKİZ	ALLAHDİYAN	185
370	İZMİR	SALİHLİ	38 26 36	28 05 32	ALLAHDİYEN	AYSEKİZ	185
371	İZMİR	MANİSA	38 42 28	28 15 08	ÇAKMAK	ÇÖRÇÖR	186
372	İZMİR	MANİSA	38 32 48	27 22 39	ÇÖRÇÖR	ÇAKMAK	186
373	İZMİR	MANİSA	38 42 28	28 15 08	ÇAKMAK	MANİSA	187
374	İZMİR	MANİSA	38 37 08	27 26 03	MANİSA	ÇAKMAK	187
375	İZMİR	MANİSA	38 42 28	28 15 08	ÇAKMAK	SEYRET	188
376	İZMİR	MANİSA	38 47 13	27 20 44	SEYRET	ÇAKMAK	188
377	İZMİR	MANİSA	38 24 54	27 54 26	ÇALDAĞ	MİDİLLİ	189
378	İZMİR	MANİSA	38 23 58	27 48 47	MİDİLLİ	ÇALDAĞ	189
379	İZMİR	MANİSA	38 53 28	27 26 38	KILIÇDAĞI	SEYRET	190
	REGIONAL DIRECTORATE	DISTRICT DIRECTORATE	North (N)	East (E)	RELAY AND RADIO LINK CONNECTIONS		

380	İZMİR	MANİSA	38 47 13	27 20 44	SEYRET	KILIÇDAĞI	190
381	İZMİR	MANİSA	38 53 28	27 26 38	KILIÇDAĞI	MANİSADAĞI	191
382	İZMİR	MANİSA	38 34 01	27 27 19	MANİSADAĞI	KILIÇDAĞI	191
383	İZMİR	SALİHLİ	38 16 51	28 30 36	BAHADIR	ERENTEPE	192
384	İZMİR	SALİHLİ	38 19 39	28 23 43	ERENTEPE	BAHADIR	192
385	İZMİR	SALİHLİ	38 16 51	28 30 36	BAHADIR	KEPEZ	193
386	İZMİR	SALİHLİ	38 10 27	28 37 43	KEPEZ	BAHADIR	193
387	İZMİR	SALİHLİ	38 38 00	28 37 15	DİRGENTEPE	ERENTEPE	194
388	İZMİR	SALİHLİ	38 19 39	28 23 43	ERENTEPE	DİRGENTEPE	194
389	İZMİR	SOMA	39 18 48	27 29 11	BOZTEPE	DENİŞ	195
390	İZMİR	SOMA	39 15 40	27 43 15	DENİŞ	BOZTEPE	195
391	İZMİR	SOMA	39 15 40	27 43 15	DENİŞ	SİLEDİK	196
392	İZMİR	SOMA	39 09 25	27 46 59	SİLEDİK	DENİŞ	196
393	İZMİR	SOMA	39 15 40	27 43 15	DENİŞ	SOMA	197
394	İZMİR	SOMA	39 11 00	27 36 31	SOMA	DENİŞ	197
395	BALIKESİR	ALAÇAM	39 41 08	28 27 15	ERİKLİ	GÖZTEPE	198
396	BALIKESİR	BALIKESİR	39 40 39	28 23 07	GÖZTEPE	ERİKLİ	198
397	BALIKESİR	ALAÇAM	39 41 08	28 27 15	ERİKLİ	PALAMUTLUK	199
398	BALIKESİR	ALAÇAM	39 39 50	28 35 39	PALAMUTLUK	ERİKLİ	199
399	BALIKESİR	ALAÇAM	39 39 50	28 35 39	PALAMUTLUK	BALDIRGANLI	200
400	BALIKESİR	DURSUNBEY	39 44 08	28 40 48	BALDIRGANLI	PALAMUTLUK	200
401	BALIKESİR	ALAÇAM	39 39 50	28 35 39	PALAMUTLUK	KOCABELEN	201
402	BALIKESİR	DURSUNBEY	39 40 56	28 44 26	KOCABELEN	PALAMUTLUK	201
403	BALIKESİR	ALAÇAM	39 39 50	28 35 39	PALAMUTLUK	DURSUNBEY	202
404	BALIKESİR	DURSUNBEY	39 34 51	28 37 50	DURSUNBEY	PALAMUTLUK	202
405	BALIKESİR	ALAÇAM	39 26 02	28 30 58	KARAVELİ	AKTUZLA	203
406	BALIKESİR	BİGADIÇ	39 24 21	28 32 53	AKTUZLA	KARAVELİ	203
407	BALIKESİR	ALAÇAM	39 28 31	28 39 04	GÜĞÜ	HACIKERİM	204
408	BALIKESİR	ALAÇAM	39 22 59	28 36 46	HACIKERİM	GÜĞÜ	204
409	BALIKESİR	ALAÇAM	39 22 59	28 36 46	HACIKERİM	AKTUZLA	205
410	BALIKESİR	BİGADIÇ	39 24 21	28 32 53	AKTUZLA	HACIKERİM	205
411	BALIKESİR	ALAÇAM	39 22 59	28 36 46	HACIKERİM	EĞREKYERİ	206
412	BALIKESİR	BİGADIÇ	39 20 59	28 38 16	EĞREKYERİ	HACIKERİM	206
413	BALIKESİR	ALAÇAM	39 22 59	28 36 46	HACIKERİM	FENERTEPE	207
414	BALIKESİR	SINDIRGI	39 17 25	28 36 19	FENERTEPE	HACIKERİM	207
415	BALIKESİR	ALAÇAM	39 34 13	28 19 51	IŞIKLAR	AKÇAKERTİL	208
416	BALIKESİR	BALIKESİR	39 32 46	28 13 16	AKÇAKERTİL	IŞIKLAR	208
417	BALIKESİR	ALAÇAM	39 34 13	28 19 51	IŞIKLAR	GÖZTEPE	209
418	BALIKESİR	BALIKESİR	39 40 39	28 23 07	GÖZTEPE	IŞIKLAR	209
419	BALIKESİR	BALIKESİR	39 41 52	27 57 50	DEĞİRMENBOĞAZI	BALIKESİR	210
420	BALIKESİR	BALIKESİR	39 38 48	27 53 10	BALIKESİR	DEĞİRMENBOĞAZI	210
421	BALIKESİR	BALIKESİR	39 32 46	28 13 16	AKÇAKERTİL	BALIKESİR	211
422	BALIKESİR	BALIKESİR	39 38 48	27 53 10	BALIKESİR	AKÇAKERTİL	211
423	BALIKESİR	BALIKESİR	39 32 46	28 13 16	AKÇAKERTİL	BİGADIÇ	212
424	BALIKESİR	BİGADIÇ	39 23 50	28 07 46	BİGADIÇ	AKÇAKERTİL	212
425	BALIKESİR	BALIKESİR	39 32 46	28 13 16	AKÇAKERTİL	İMROZ	213
426	BALIKESİR	BİGADIÇ	39 22 03	28 18 27	İMROZ	AKÇAKERTİL	213
427	BALIKESİR	BALIKESİR	39 47 20	28 15 40	SAZAK	ÇATALDAĞ	214
428	BALIKESİR	BANDIRMA	39 53 53	28 15 44	ÇATALDAĞ	SAZAK	214

429	BALIKESİR	BALIKESİR	39 47 20	28 15 40	SAZAK	SEÇTEPE	215
430	BALIKESİR	BALIKESİR	39 44 29	28 22 47	SEÇTEPE	SAZAK	215
431	BALIKESİR	BALIKESİR	39 40 39	28 23 07	GÖZTEPE	SEÇTEPE	216
432	BALIKESİR	BALIKESİR	39 44 29	28 22 47	SEÇTEPE	GÖZTEPE	216
433	BALIKESİR	BALIKESİR	39 47 44	27 43 23	ÜRKÜTTEPE	GÜCÜYEN	217
434	BALIKESİR	İVRİNDİ	39 52 46	27 37 25	GÜCÜYEN	ÜRKÜTTEPE	217
	REGIONAL DIRECTORATE	DISTRICT DIRECTORATE	North (N)	East (E)	RELAY AND RADIO LINK CONNECTIONS		
435	BALIKESİR	BALIKESİR	39 26 20	27 45 49	KALETEPE	KOCATAŞ	218
436	BALIKESİR	İVRİNDİ	39 36 29	27 36 53	KOCATAŞ	KALETEPE	218
437	BALIKESİR	BALIKESİR	39 26 20	27 45 49	KALETEPE	TÜRKMENTEPE	219
438	BALIKESİR	BALIKESİR	39 24 25	27 32 30	TÜRKMENTEPE	KALETEPE	219
439	BALIKESİR	BALIKESİR	39 26 20	27 45 49	KALETEPE	DUMANLI	220
440	BALIKESİR	BALIKESİR	39 21 40	27 49 36	DUMANLI	KALETEPE	220
441	BALIKESİR	BALIKESİR	39 21 09	27 53 49	KURUTEPE	DUMANLI	221
442	BALIKESİR	BALIKESİR	39 21 40	27 49 36	DUMANLI	KURUTEPE	221
443	BALIKESİR	BALIKESİR	39 21 09	27 53 49	KURUTEPE	KERTİL	222
444	BALIKESİR	SINDIRGI	39 12 38	28 05 49	KERTİL	KURUTEPE	222
445	BALIKESİR	BALIKESİR	39 24 25	27 32 30	TÜRKMENTEPE	ÇAVDARLIK	223
446	BALIKESİR	İVRİNDİ	39 22 07	27 14 34	ÇAVDARLIK	TÜRKMENTEPE	223
447	BALIKESİR	BANDIRMA	40 21 46	28 10 55	NALDÖKEN	ÇATALDAĞ	224
448	BALIKESİR	BANDIRMA	39 53 53	28 15 44	ÇATALDAĞ	NALDÖKEN	224
449	BALIKESİR	BANDIRMA	40 21 46	28 10 55	NALDÖKEN	BANDIRMA	225
450	BALIKESİR	BANDIRMA	42 20 09	27 59 22	BANDIRMA	NALDÖKEN	225
451	BALIKESİR	BANDIRMA	40 21 46	28 10 55	NALDÖKEN	MAĞARATEPE	226
452	BALIKESİR	BANDIRMA	40 24 58	27 48 14	MAĞARATEPE	NALDÖKEN	226
453	BALIKESİR	BANDIRMA	40 24 58	27 48 14	MAĞARATEPE	SARIKÖY	227
454	BALIKESİR	GÖNEN	40 12 57	27 29 10	SARIKÖY	MAĞARATEPE	227
455	BALIKESİR	BANDIRMA	40 36 40	27 35 13	MARMARA ADASI	SARIKÖY	228
456	BALIKESİR	GÖNEN	40 12 57	27 29 10	SARIKÖY	MARMARA ADASI	228
457	BALIKESİR	BİGADIÇ	39 22 03	28 18 27	İMROZ	ÇALDOĞRUSU	229
458	BALIKESİR	BİGADIÇ	39 21 46	28 24 04	ÇALDOĞRUSU	İMROZ	229
459	BALIKESİR	BİGADIÇ	39 22 03	28 18 27	İMROZ	ALİÇO	230
460	BALIKESİR	BİGADIÇ	39 19 10	28 20 19	ALİÇO	İMROZ	230
461	BALIKESİR	BİGADIÇ	39 19 10	28 20 19	ALİÇO	DEDEKIRAN	231
462	BALIKESİR	SINDIRGI	39 09 53	28 25 01	DEDEKIRAN	ALİÇO	231
463	BALIKESİR	BİGADIÇ	39 22 14	28 30 23	BEYDAĞ	FENERTEPE	232
464	BALIKESİR	SINDIRGI	39 17 25	28 36 19	FENERTEPE	BEYDAĞ	232
465	BALIKESİR	BİGADIÇ	39 20 59	28 38 16	EĞREKYERİ	ARMUTBURUN	233
466	BALIKESİR	DURSUNBEY	39 19 14	28 46 05	ARMUTBURUN	EĞREKYERİ	233
467	BALIKESİR	DURSUNBEY	39 31 39	28 49 06	ASARLIK	KOCABELEN	234
468	BALIKESİR	DURSUNBEY	39 40 56	28 44 26	KOCABELEN	ASARLIK	234
469	BALIKESİR	DURSUNBEY	39 31 39	28 49 06	ASARLIK	ALFA	235
470	BALIKESİR	DURSUNBEY	39 27 56	28 55 21	ALFA	ASARLIK	235
471	BALIKESİR	DURSUNBEY	39 25 27	28 44 53	KILIÇOLUK	CİVANA	236
472	BALIKESİR	DURSUNBEY	39 22 43	28 51 31	CİVANA	KILIÇOLUK	236
473	BALIKESİR	DURSUNBEY	39 25 27	28 44 53	KILIÇOLUK	TEPEPINAR	237
474	BALIKESİR	DURSUNBEY	39 29 05	28 44 59	TEPEPINAR	KILIÇOLUK	237
475	BALIKESİR	DURSUNBEY	39 27 56	28 55 21	ALFA	CİVANA	238
476	BALIKESİR	DURSUNBEY	39 22 43	28 51 31	CİVANA	ALFA	238
477	BALIKESİR	DURSUNBEY	39 21 34	28 52 48	KUYUGEDİĞİ	CİVANA	239

478	BALIKESİR	DURSUNBEY	39 22 43	28 51 31	CIVANA	<i>KUYUGEDİĞİ</i>	239
479	BALIKESİR	DURSUNBEY	39 21 34	28 52 48	KUYUGEDİĞİ	ARMUTBURUN	240
480	BALIKESİR	DURSUNBEY	39 19 14	28 46 05	ARMUTBURUN	KUYUGEDİĞİ	240
481	BALIKESİR	DURSUNBEY	39 34 51	28 37 51	DURSUNBEY	PALAMUTLUK	241
482	BALIKESİR	DURSUNBEY	39 39 51	28 35 39	PALAMUTLUK	DURSUNBEY	241
483	BALIKESİR	EDREMİT	39 39 10	26 44 00	KARAÇAM	ZEYBEK	242
484	BALIKESİR	EDREMİT	39 38 30	26 47 38	ZEYBEK	KARAÇAM	242
485	BALIKESİR	EDREMİT	39 39 10	26 44 00	KARAÇAM	DİKİLİ-ÇKALE	243
486	ÇANAKKALE	AYVACIK	39 35 22	26 33 22	DİKİLİ	KARAÇAM-BALIKESİR	243
487	BALIKESİR	EDREMİT	39 16 39	26 39 32	ÇAMLIK	BAYRAK	244
488	BALIKESİR	EDREMİT	39 19 10	26 53 26	BAYRAK	ÇAMLIK	244
489	BALIKESİR	EDREMİT	39 19 10	26 53 26	BAYRAK	ZEYBEK	245
	REGIONAL DIRECTORATE	DISTRICT DIRECTORATE	North (N)	East (E)	RELAY AND RADIO LINK CONNECTIONS		
490	BALIKESİR	EDREMİT	39 38 30	26 47 38	ZEYBEK	BAYRAK	245
491	BALIKESİR	EDREMİT	39 28 40	26 58 02	SEKLİK	ZEYBEK	246
492	BALIKESİR	EDREMİT	39 38 30	26 47 38	ZEYBEK	SEKLİK	246
493	BALIKESİR	EDREMİT	39 28 40	26 58 02	SEKLİK	GÜVEN	247
494	BALIKESİR	EDREMİT	39 24 55	27 05 13	GÜVEN	SEKLİK	247
495	BALIKESİR	EDREMİT	39 28 40	26 58 02	SEKLİK	KARADAĞ	248
496	BALIKESİR	EDREMİT	39 38 02	27 00 44	KARADAĞ	SEKLİK	248
497	BALIKESİR	EDREMİT	39 40 54	26 54 57	KAPI	KARADAĞ	249
498	BALIKESİR	EDREMİT	39 38 02	27 00 44	KARADAĞ	KAPI	249
499	BALIKESİR	EDREMİT	39 40 54	26 54 57	KAPI	İKİZCETEPE	250
500	BALIKESİR	İVRİNDİ	39 42 38	27 22 20	İKİZCETEPE	KAPI	250
501	BALIKESİR	EDREMİT	39 38 51	27 19 10	BAKACAK	İKİZCETEPE	251
502	BALIKESİR	İVRİNDİ	39 42 38	27 22 20	İKİZCETEPE	BAKACAK	251
503	BALIKESİR	EDREMİT	39 31 18	27 07 40	KOCADAĞ	SEKLİK	252
504	BALIKESİR	EDREMİT	39 28 40	26 58 02	SEKLİK	KOCADAĞ	252
505	BALIKESİR	EDREMİT	39 31 18	27 07 40	KOCADAĞ	GÖKTEPE	253
506	BALIKESİR	İVRİNDİ	39 25 53	27 13 23	GÖKTEPE	KOCADAĞ	253
507	BALIKESİR	EDREMİT	39 38 02	27 00 44	KARADAĞ	EDREMİT	254
508	BALIKESİR	EDREMİT	39 35 15	27 01 29	EDREMİT	KARADAĞ	254
509	BALIKESİR	GÖNEN	39 59 24	27 33 45	DİKMEN	GÜCÜYEN	255
510	BALIKESİR	İVRİNDİ	39 52 46	27 37 25	GÜCÜYEN	DİKMEN	255
511	BALIKESİR	GÖNEN	39 59 24	27 33 45	DİKMEN	SARIKÖY	256
512	BALIKESİR	GÖNEN	40 12 57	27 29 10	SARIKÖY	DİKMEN	256
513	BALIKESİR	GÖNEN	39 59 24	27 33 45	DİKMEN	GÖNEN	257
514	BALIKESİR	GÖNEN	40 06 39	27 39 14	GÖNEN	DİKMEN	257
515	BALIKESİR	İVRİNDİ	39 36 29	27 36 53	KOCATAŞ	İVRİNDİ	258
516	BALIKESİR	İVRİNDİ	39 34 53	27 29 36	İVRİNDİ	KOCATAŞ	258
517	BALIKESİR	İVRİNDİ	39 44 26	27 37 11	AKÇAL	İKİZCETEPE	259
518	BALIKESİR	İVRİNDİ	39 42 38	27 22 20	İKİZCETEPE	AKÇAL	259
519	BALIKESİR	İVRİNDİ	39 44 26	27 37 11	AKÇAL	GÜCÜYEN	260
520	BALIKESİR	İVRİNDİ	39 52 46	27 37 25	GÜCÜYEN	AKÇAL	260
521	BALIKESİR	İVRİNDİ	39 42 38	27 22 20	İKİZCETEPE	KAVSARA	261
522	ÇANAKKALE	KALKIM	39 42 13	27 11 58	KAVSARA	İKİZCETEPE	261
523	BALIKESİR	İVRİNDİ	39 22 07	27 14 34	ÇAVDARLIK	GÖKTEPE	262
524	BALIKESİR	İVRİNDİ	39 25 53	27 13 23	GÖKTEPE	ÇAVDARLIK	262

525	BALIKESİR	İVRİNDİ	39 25 53	27 13 23	GÖKTEPE	ASARLIK	263
526	BALIKESİR	İVRİNDİ	39 25 41	27 21 20	ASARLIK	GÖKTEPE	263
527	BALIKESİR	SINDIRGI	39 07 57	28 31 19	KEPEZ	GÖKSEKİ	264
528	BALIKESİR	SINDIRGI	39 04 49	28 16 23	GÖKSEKİ	KEPEZ	264
529	BALIKESİR	SINDIRGI	39 07 57	28 31 19	KEPEZ	FENERTEPE	265
530	BALIKESİR	SINDIRGI	39 17 25	28 36 19	FENERTEPE	KEPEZ	265
531	BALIKESİR	SINDIRGI	39 09 53	28 25 01	DEDEKIRAN	GÖKSEKİ	266
532	BALIKESİR	SINDIRGI	39 04 49	28 16 23	GÖKSEKİ	DEDEKIRAN	266
533	BALIKESİR	SINDIRGI	39 09 53	28 25 01	DEDEKIRAN	ULUS	267
534	BALIKESİR	SINDIRGI	39 18 59	28 23 20	ULUS	DEDEKIRAN	267
535	BALIKESİR	SINDIRGI	39 12 38	28 05 49	KERTİL	GÖKSEKİ	268
536	BALIKESİR	SINDIRGI	39 04 49	28 16 23	GÖKSEKİ	KERTİL	268
537	BALIKESİR	SINDIRGI	39 14 27	28 10 29	SINDIRGI	KERTİL	269
538	BALIKESİR	SINDIRGI	39 12 38	28 05 49	KERTİL	SINDIRGI	269
539	ÇANAKKALE	ANAFARTALAR	40 28 07	26 35 15	ÇAMAKTEPEEKİP	İBRİCE	270
540	ÇANAKKALE	KEŞAN	40 38 54	26 35 38	İBRİCE	ÇAMAKTEPEEKİP	270
541	ÇANAKKALE	ANAFARTALAR	40 24 36	26 40 44	GELİBOLU	KISIK	271
542	ÇANAKKALE	KEŞAN	40 41 50	26 46 05	KISIK	GELİBOLU	271
543	ÇANAKKALE	ANAFARTALAR	40 24 36	26 40 44	GELİBOLU	BEDESTAN	272
544	ÇANAKKALE	ÇANAKKALE	40 20 16	26 52 26	BEDESTAN	GELİBOLU	272
	REGIONAL DIRECTORATE	DISTRICT DIRECTORATE	North (N)	East (E)	RELAY AND RADIO LINK CONNECTIONS		
545	ÇANAKKALE	AYVACIK	39 35 58	26 24 28	AYVACIK	DİKİLİ	273
546	ÇANAKKALE	AYVACIK	39 35 22	26 33 22	DİKİLİ	AYVACIK	273
547	ÇANAKKALE	AYVACIK	39 53 42	26 25 17	ÇAMLICA	EZİNE	274
548	ÇANAKKALE	AYVACIK	39 47 22	26 20 04	EZİNE	ÇAMLICA	274
549	ÇANAKKALE	AYVACIK	39 53 42	26 25 17	ÇAMLICA	B.ASMATEPE	275
550	ÇANAKKALE	BAYRAMIÇ	39 56 26	26 33 26	B.ASMATEPE	ÇAMLICA	275
551	ÇANAKKALE	AYVACIK	39 35 22	26 33 22	DİKİLİ	KAVAKDAĞ	276
552	ÇANAKKALE	AYVACIK	39 35 02	26 14 56	KAVAKDAĞ	DİKİLİ	276
553	ÇANAKKALE	AYVACIK	39 35 22	26 33 22	DİKİLİ	KKUYU	277
554	ÇANAKKALE	AYVACIK	39 32 54	26 36 27	KKUYU	DİKİLİ	277
555	ÇANAKKALE	AYVACIK	39 35 22	26 33 22	DİKİLİ	MEKKARE	278
556	ÇANAKKALE	BAYRAMIÇ	39 43 09	26 45 36	MEKKARE	DİKİLİ	278
557	ÇANAKKALE	BAYRAMIÇ	39 56 26	26 33 26	B.ASMATEPE	KAYALIDAĞ	279
558	ÇANAKKALE	ÇANAKKALE	39 57 59	26 38 10	KAYALIDAĞ	B.ASMATEPE	279
559	ÇANAKKALE	BAYRAMIÇ	39 56 26	26 33 26	B.ASMATEPE	ÇANAKALAN	280
560	ÇANAKKALE	ÇANAKKALE	40 01 32	26 25 19	ÇANAKALAN	B.ASMATEPE	280
561	ÇANAKKALE	BAYRAMIÇ	39 56 26	26 33 26	B.ASMATEPE	KUŞAKLICA	281
562	ÇANAKKALE	BAYRAMIÇ	39 54 05	26 35 14	KUŞAKLICA	B.ASMATEPE	281
563	ÇANAKKALE	BAYRAMIÇ	39 56 28	26 33 26	BAYRAMIÇ	KUŞAKLICA	282
564	ÇANAKKALE	BAYRAMIÇ	39 54 05	26 35 14	KUŞAKLICA	BAYRAMIÇ	282
565	ÇANAKKALE	BAYRAMIÇ	39 50 03	26 51 04	KOCAKIR DEPO	MEKKARE	283
566	ÇANAKKALE	BAYRAMIÇ	39 43 09	26 45 36	MEKKARE	KOCAKIR DEPO	283
567	ÇANAKKALE	BAYRAMIÇ	39 43 09	26 45 36	MEKKARE	SÖĞÜTGEDİĞİ	284
568	ÇANAKKALE	BAYRAMIÇ	39 56 39	26 45 04	SÖĞÜTGEDİĞİ	MEKKARE	284
569	ÇANAKKALE	BAYRAMIÇ	39 43 09	26 45 36	MEKKARE	ZEYBEKÇAYIRI EKİP	285
570	ÇANAKKALE	ÇAN	39 52 53	27 00 37	ZEYBEKÇAYIRI EKİP	MEKKARE	285
571	ÇANAKKALE	BAYRAMIÇ	39 56 39	26 45 04	SÖĞÜTGEDİĞİ	KAYALIDAĞ	286
572	ÇANAKKALE	ÇANAKKALE	39 57 59	26 38 10	KAYALIDAĞ	SÖĞÜTGEDİĞİ	286
573	ÇANAKKALE	BİGA	40 13 01	27 14 23	BİGA	KARTAL	287

574	ÇANAKKALE	BİGA	40 09 55	27 18 10	KARTAL	BİGA	287
575	ÇANAKKALE	BİGA	40 23 27	27 11 26	DEDETEPE	KARTAL	288
576	ÇANAKKALE	BİGA	40 09 55	27 18 10	KARTAL	DEDETEPE	288
577	ÇANAKKALE	BİGA	40 09 55	27 18 10	KARTAL	KOCATEPE	289
578	ÇANAKKALE	BİGA	40 21 08	27 01 56	KOCATEPE	KARTAL	289
579	ÇANAKKALE	BİGA	40 09 55	27 18 10	KARTAL	ERENLER	290
580	ÇANAKKALE	ÇAN	40 00 49	27 04 21	ERENLER	KARTAL	290
581	ÇANAKKALE	BİGA	40 21 08	27 01 56	KOCATEPE	DUMANLI	291
582	ÇANAKKALE	ÇANAKKALE	40 16 49	26 53 11	DUMANLI	KAOCATEPE	291
583	ÇANAKKALE	ÇAN	40 01 42	27 02 59	ÇAN	ERENLER	292
584	ÇANAKKALE	ÇAN	40 00 49	27 04 21	ERENLER	ÇAN	292
585	ÇANAKKALE	ÇAN	40 00 49	27 04 21	ERENLER	KİREÇTEPE	293
586	ÇANAKKALE	YENİCE	39 53 50	27 13 03	KİREÇTEPE	ERENLER	293
587	ÇANAKKALE	ÇANAKKALE	40 08 39	26 40 00	AĞIDAĞI	ASMATEPE	294
588	ÇANAKKALE	ÇANAKKALE	40 06 23	26 26 39	ASMATEPE	AĞIDAĞI	294
589	ÇANAKKALE	ÇANAKKALE	40 08 39	26 40 00	AĞIDAĞI	DUMANLI	295
590	ÇANAKKALE	ÇANAKKALE	40 16 49	26 53 11	DUMANLI	AĞIDAĞI	295
591	ÇANAKKALE	ÇANAKKALE	40 06 23	26 26 39	ASMATEPE	ÇİMENTEPE	296
592	ÇANAKKALE	ANAFARTALAR	40 15 32	26 19 10	ÇİMENTEPE	ASMATEPE	296
593	ÇANAKKALE	ÇANAKKALE	40 06 23	26 26 39	ASMATEPE	ÇKALEOBM	297
594	ÇANAKKALE	ÇANAKKALE	40 09 21	26 24 44	ÇKALEOBM	ASMATEPE	297
595	ÇANAKKALE	ÇANAKKALE	40 06 23	26 26 39	ASMATEPE	ANAFARTALAR	298
596	ÇANAKKALE	ANAFARTALAR	40 10 47	26 21 39	ANAFARTALAR	ASMATEPE	298
597	ÇANAKKALE	ÇANAKKALE	40 20 16	26 52 26	BEDESTAN	DUMANLI	299
598	ÇANAKKALE	ÇANAKKALE	40 16 49	26 53 11	DUMANLI	BEDESTAN	299
599	ÇANAKKALE	ANAFARTALAR	40 15 32	26 19 10	ÇİMENTEPE	PAZARLI	300
	REGIONAL DIRECTORATE	DISTRICT DIRECTORATE	North (N)	East (E)	RELAY AND RADIO LINK CONNECTIONS		
600	ÇANAKKALE	ANAFARTALAR	40 20 48	26 29 41	PAZARLI	ÇİMENTEPE	300
601	ÇANAKKALE	ÇANAKKALE	39 57 59	26 38 10	KAYALIDAĞ	KİRAZLI DEPO	301
602	ÇANAKKALE	ÇANAKKALE	40 02 20	26 39 50	KİRAZLI DEPO	KAYALIDAĞ	301
603	ÇANAKKALE	ANAFARTALAR	40 20 48	26 29 41	PAZARLI	KISIK	302
604	ÇANAKKALE	KEŞAN	40 41 50	26 46 05	KISIK	PAZARLI	302
605	ÇANAKKALE	KALKIM	39 48 38	27 12 38	KALKIM	KİREÇTEPE	303
606	ÇANAKKALE	YENİCE	39 53 50	27 13 03	KİREÇTEPE	KALKIM	303
607	ÇANAKKALE	KALKIM	39 42 13	27 11 58	KAVSARA	HASANLAR	304
608	ÇANAKKALE	YENİCE	39 47 34	27 24 40	HASANLAR	KAVSARA	304
609	ÇANAKKALE	KEŞAN	40 43 16	26 30 49	HIZIRIYASTEPE	KISIK	305
610	ÇANAKKALE	KEŞAN	40 41 50	26 46 05	KISIK	HIZIRIYASTEPE	305
611	ÇANAKKALE	KEŞAN	40 43 16	26 30 49	HIZIRIYASTEPE	İBRİCE	306
612	ÇANAKKALE	KEŞAN	40 38 54	26 35 38	İBRİCE	HIZIRIYASTEPE	306
613	ÇANAKKALE	KEŞAN	40 43 16	26 30 49	HIZIRIYASTEPE	HİSARDAĞ	307
614	ÇANAKKALE	KEŞAN	40 43 19	26 10 26	HİSARDAĞ	HIZIRIYASTEPE	307
615	ÇANAKKALE	KEŞAN	40 49 23	26 40 48	KALETEPE	KISIK	308
616	ÇANAKKALE	KEŞAN	40 41 50	26 46 05	KISIK	KALETEPE	308
617	ÇANAKKALE	KEŞAN	40 49 23	26 40 48	KALETEPE	KEŞAN	309
618	ÇANAKKALE	KEŞAN	40 50 17	26 37 45	KEŞAN	KALETEPE	309
619	ÇANAKKALE	YENİCE	40 01 24	27 24 39	BALDAĞ	HASANLAR	310
620	ÇANAKKALE	YENİCE	39 47 34	27 24 40	HASANLAR	BALDAĞ	310

621	ÇANAKKALE	YENİCE	39 47 34	27 24 40	HASANLAR	KİREÇTEPE	311
622	ÇANAKKALE	YENİCE	39 53 50	27 13 03	KİREÇTEPE	HASANLAR	311
623	ÇANAKKALE	YENİCE	39 53 50	27 13 03	KİREÇTEPE	YENİCE	312
624	ÇANAKKALE	YENİCE	39 56 03	27 15 32	YENİCE	KİREÇTEPE	312

APPENDIX 2: CONTAINER AND SOLAR ENERGY SYSTEM LAYOUT PLAN

Draft Document

OGM SAMPLE FIELD SETUP PLAN

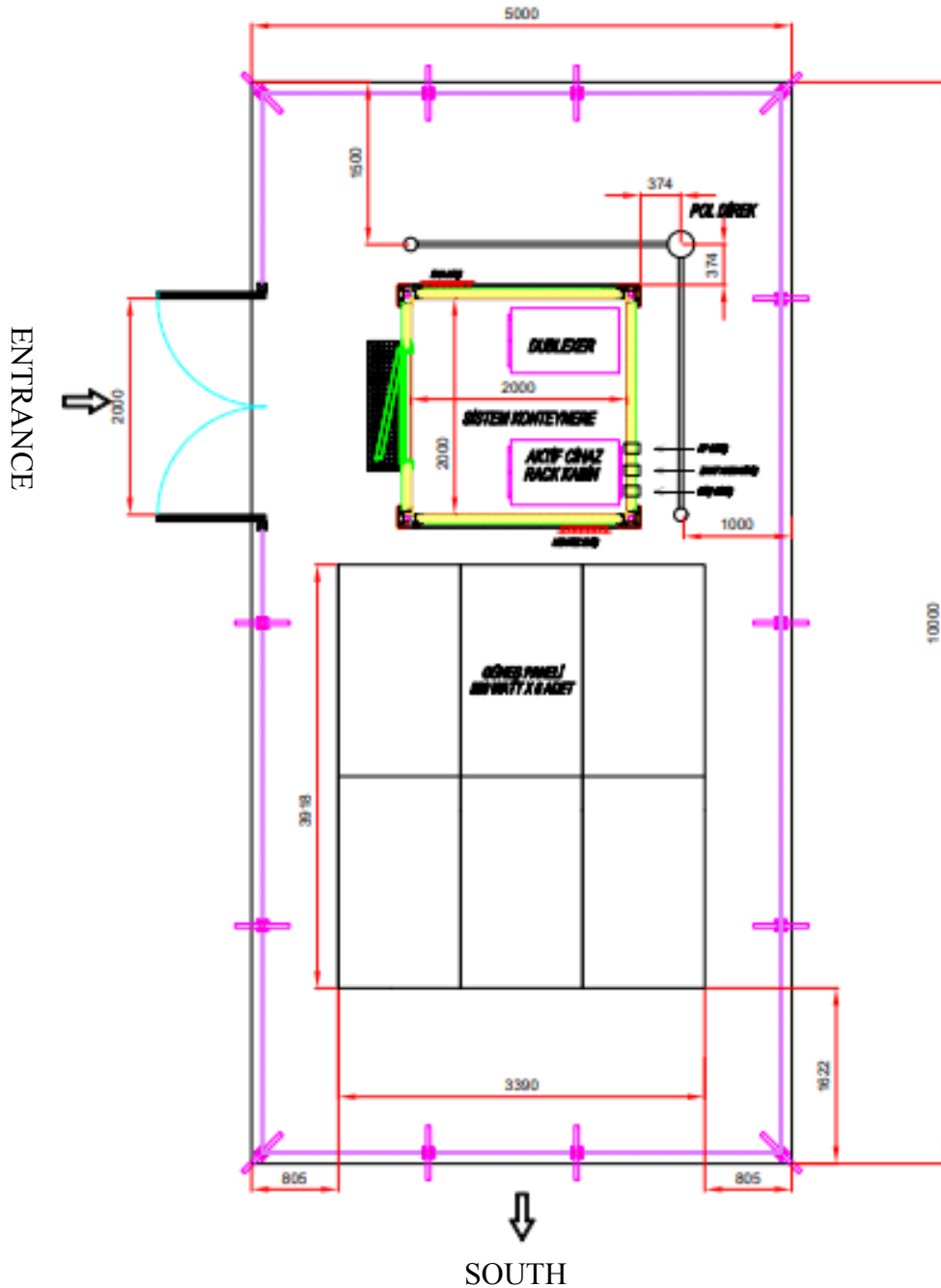

NOTES:

- 1- Solar panels will be mounted facing south at a 35-degree angle. The dimensions in the drawing are scaled to 0.8 (cos 35) times the actual size.
- 2- Solar panels will be raised above the shadow cast by the fence.
- 3- The top level of the solar panels will be higher than the height of the container.

APPENDIX 3: PANEL FENCE DETAIL

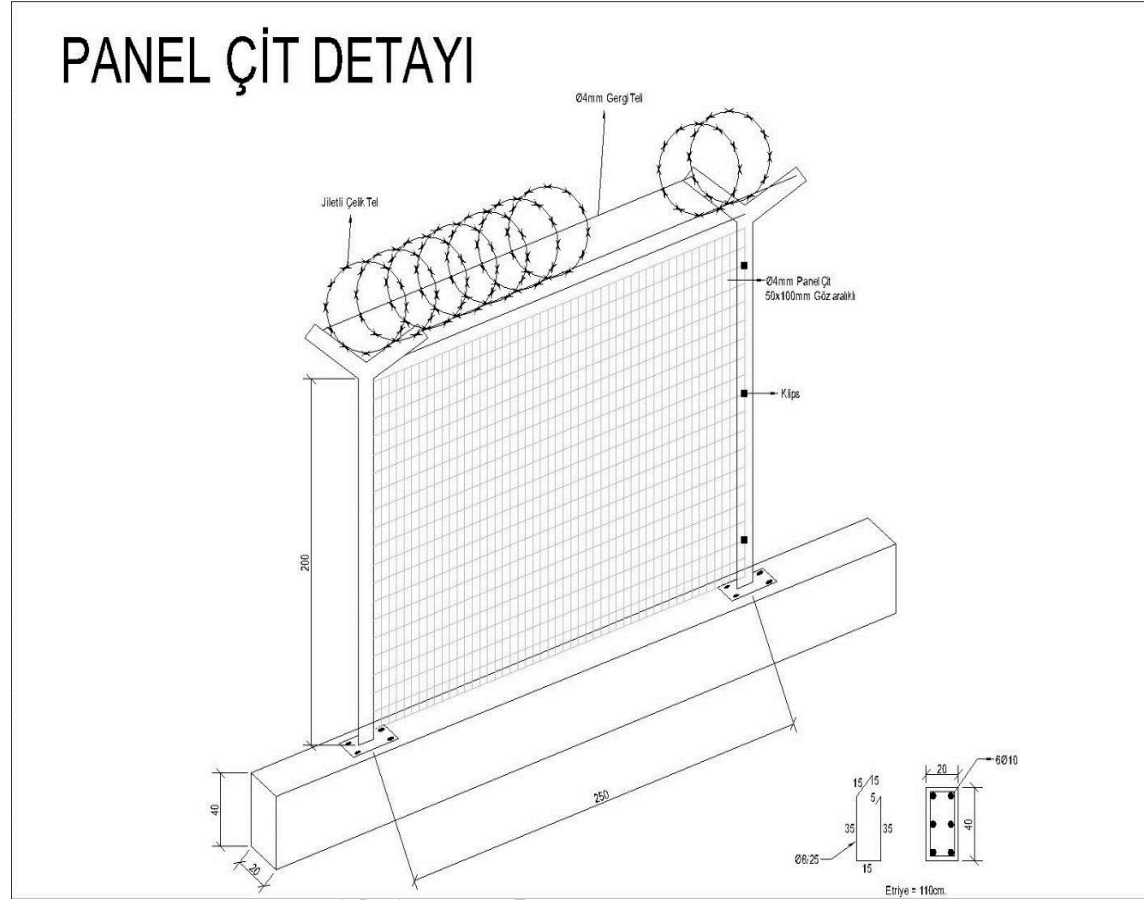

Critical Technical Specifications

- 1- Handheld, mobile, fixed radios and relay will operate in the 34-36 MHz frequency band of the VHF band,
- 2- The radios will have the capacity to make both digital and analog radio communications, and work smoothly in digital-analog mode with the Purchaser's existing digital-analog radios.
- 3- Handheld, vehicle, and fixed radios will have an internal GPS module and will automatically transmit location information in digital mode. Coordinate information will also be visible via the radio in output power of the handheld radio is 5W; the output power of mobile and fixed radios can be up to 25W, and the output power of relay radios can be up to 50W.
- 4- The radio will have an IP54 protection rating.
- 5- Batteries for handheld radios shall have a capacity of at least 1900 mAh.
- 6- The signal attenuation rate of the bandpass part will be at least -2 dB, and the signal suppression rate of the band stop part will be at most -80 dB (for duplexer)
- 7- The wireless communication system will operate on suitable Tx and Rx frequencies allocated to the Purchaser in the 10.5 GHz band for long-distance links, based on links planned with a professional planning program according to 99.95% availability principles.
- 8- The wireless communication system to be established will have a minimum capacity of 100 Mbps in all directions and will be configured in a 1+0 configuration. (for R/L)
- 9- Each indoor unit must have at least 4 Fast Ethernet ports, these ports must be able to operate in a group and independently of each other (for R/L)
- 10- The cabinets must have a ventilation system consisting of 4 fans and a temperature-adjustable thermal control circuit.
- 11- The solar panels, charge control unit, inverter and batteries to be offered will comply with at least one of the international standards IEC, VDE, DIN and the standard followed will be specified in the offer.
- 12- The charge control unit and converter (inverter) will be offered as separate devices. They will not be integrated and will be hot-swappable.
- 13- The charge control unit will be reactivated as a result of the protection it provides during overcharging or discharging of battery groups

4. Drawings

This bidding document includes *the following* drawings.

List of Drawings		
Drawing Nr.	Drawing Name	Purpose
1	Container And Solar Energy System Layout Plan	
2	Panel Fence Detail	

5. Inspections and Tests

The following inspections and tests shall be performed:

1. Technical compliance checks against the Technical Specification clauses one by one
2. Functional and performance tests, where required
3. Factory Acceptance Tests, where applicable
4. Inspection of packing and marking
5. Upon completion of delivery and installation/commissioning, the Goods and the system shall be inspected and accepted to verify compliance with the Contract and the Technical Specifications. Any required tests shall be carried out, and any non-conformities identified shall be remedied prior to final acceptance.

Draft Document